



NVIDIA ConnectX-9 SuperNIC User Manual

Table of Contents

1	Introduction.....	8
1.1	Product Overview	8
1.2	ConnectX-9 Extension Options	8
1.2.1	Socket Direct SuperNICs	8
1.2.2	Down Stream Port (DSP)	9
1.2.3	Port Splitting.....	9
1.3	System Requirements	9
1.4	Package Contents	9
1.5	Features and Benefits.....	11
2	Supported Interfaces	15
2.1	ConnectX-9 Layout and Interface Information	15
2.2	Interfaces Detailed Description	16
2.2.1	ConnectX-9 IC	16
2.2.2	Host Interface	16
2.2.3	Networking Interfaces.....	17
2.2.4	Networking Ports LEDs Specifications.....	17
2.2.4.1	Scheme 1: One Bi-Color LED.....	17
2.2.4.2	Scheme 2: Two LEDs	19
2.2.5	MCIO Connector	19
2.2.6	Sideband Management Interface	20
2.2.6.1	ConnectX-9 Cable Extender Debugging Kit	21
2.3	Pinouts Description	21
2.3.1	NC-SI Sideband Interface	21
2.3.2	MCIO Interface	22
2.3.2.1	Default (Socket-Direct/Multi-Host) Pinouts for 900-9X91E-00EB-ST0 and 900-9X91Q-00CN-ST0 SuperNICs.....	23
2.3.2.2	Switch Mode Pinouts for 900-9X91E-00EB-DT0 SuperNICs.....	26
3	Hardware Installation	30
3.1	Safety Warnings	30
3.2	Installation Procedure Overview	31
3.3	System Requirements	31
3.4	Safety Precautions Before Installing ConnectX-9 SuperNIC	32
3.4.1	Power Down and Disconnect	33

3.4.2	Electrostatic Discharge (ESD) Prevention	33
3.4.3	Handle Components with Care.....	33
3.4.4	Proper Grounding	33
3.4.5	Environmental Safety.....	33
3.5	Pre-Installation Checklist	33
3.6	Bracket Replacement Instructions	34
3.7	Installation Instructions.....	35
3.7.1	Cables and Modules.....	35
3.8	Identifying the SuperNIC in Your System	36
3.9	ConnectX-9 PCIe x16 Installation Instructions.....	37
3.9.1	Preparation	37
3.9.2	Install the ConnectX-9 SuperNIC.....	38
3.9.3	Connect Power and Cables	39
3.9.4	Power On and Verify the Installation	39
3.9.5	Uninstallation Instructions.....	39
3.9.5.1	Preparation.....	39
3.9.5.2	Open the Chassis	40
3.9.5.3	Disconnect the Networking Cable	40
3.9.5.4	Uninstall the ConnectX-9 SuperNIC.....	40
3.9.5.5	(Optional) Inspect and Clean the Components	41
3.9.5.6	Close the Chassis	41
3.9.5.7	Reconnect Power and Cables	41
3.9.5.8	Power On and Verify	41
3.10	ConnectX-9 Extension Option (2x PCIe x16) Installation Instructions	41
3.10.1	Installation Instructions.....	42
3.10.1.1	Installing the SuperNIC in the Chassis.....	42
3.10.1.2	Connecting the MCIO Harness	42
3.10.1.3	Installing the PCIe Auxiliary Card in the Chassis.....	42
3.10.1.4	Installing the Networking Cable.....	43
3.10.2	Uninstallation Instructions.....	43
3.10.2.1	Preparation.....	43
3.10.2.2	Open the Chassis	44
3.10.2.3	Disconnect the Networking Cable	44
3.10.2.4	Uninstalling the PCIe Auxiliary Card.....	44
3.10.2.5	Uninstalling the ConnectX-9 SuperNIC	46
3.10.2.6	Final Steps.....	46
3.10.2.7	Dispose of Components Properly	46

4	Driver Installation.....	47
4.1	DOCA-Host for Linux Driver Installation.....	47
4.1.1	Prerequisites.....	47
4.1.2	Downloading DOCA-Host	47
4.1.3	Installing DOCA-Host.....	48
4.2	Windows Driver Installation	48
4.2.1	Software Requirements	48
4.2.2	Downloading WinOF-2 Driver	49
4.2.3	Installing WinOF-2 Driver	49
4.2.3.1	Attended Installation	49
4.2.3.2	Unattended Installation	55
4.2.4	Firmware Upgrade	56
5	Firmware Upgrade	57
6	SuperNIC Configurations	58
6.1	Setting High-Speed-Port Link Type	58
6.1.1	mlxconfig.....	58
6.1.2	UEFI	58
6.2	PCIe Bifurcation Configuration Options	58
6.3	Port Configurations	59
6.3.1	C9180 Port-Splitting Configurations.....	62
6.3.1.1	C9180 Configuration #1 (Default): Two Ethernet Ports, Each Supporting 400GbE.....	62
6.3.1.2	C9180 Configuration #2: One InfiniBand Port, Supporting XDR 800Gb/s..	62
6.3.1.3	C9180 Configuration #3: Eight Ethernet Ports, Each Supporting 100GbE.	65
6.3.1.4	C9180 Configuration #4: One InfiniBand Port Supporting XDR Lite 400Gb/s	66
6.3.1.5	C9180 Configuration #5: Two InfiniBand Ports Supporting XDR Lite 400Gb/s.....	67
6.3.1.6	C9180 Configuration #6: One InfiniBand Port Supporting NDR 400Gb/s ..	68
6.3.1.7	C9180 Configuration #7: Two InfiniBand Ports Supporting NDR 400Gb/s .	68
6.3.1.8	C9180 Configuration #8: Four Ethernet Ports Supporting 200GbE	70
6.3.1.9	C9180 Configuration #9: One Ethernet Port Supporting 800GbE.....	70
6.3.2	C9240 Port-Splitting Configurations.....	71
6.3.2.1	C9240 Configuration #1 (Default): Two Ethernet Ports, Each Supporting 400GbE.....	71
6.3.2.2	C9240 Configuration #2: Eight Ethernet Ports, Each Supporting 100GbE.	73
6.3.2.3	C9240 Configuration #3: One InfiniBand Port Supporting XDR Lite 400Gb/s1	73
6.3.2.4	C9240 Configuration #4: Two InfiniBand Ports Supporting XDR Lite 400Gb/s.....	74

6.3.2.5	C9240 Configuration #5: One InfiniBand Port Supporting NDR 400Gb/s ..	76
6.3.2.6	C9240 Configuration #6: Two InfiniBand Ports Supporting NDR 400Gb/s .	76
6.4	Monitoring	77
6.4.1	Thermal Sensors.....	77
6.4.2	SuperNIC Heatsink	78
7	Troubleshooting	79
7.1	General Troubleshooting.....	79
7.2	Linux Troubleshooting.....	80
7.3	Windows Troubleshooting.....	81
8	Finding the GUID/MAC on the SuperNIC	82
9	Specifications.....	83
9.1	C9180 SuperNICs Specifications	84
9.2	Brackets Mechanical Drawings and Dimensions	87
10	PCIe Auxiliary Card Kit	88
10.1	PCIe Auxiliary Card Package Contents	88
10.2	Socket Direct SuperNICs	88
10.3	Down Stream Port (DSP)	89
10.4	Channel Insertion Loss	89
10.5	MCIO Harness Pinouts	89
10.6	PCIe Auxiliary Kit Technical Specifications.....	93
10.6.1	Technical Specifications	93
10.6.2	PCIe Auxiliary Card Mechanical Drawings and Dimensions.....	94
10.6.3	Bracket Mechanical Drawings and Dimensions.....	94
11	Document Revision History	95

About This Manual

This User Manual describes NVIDIA® ConnectX®-9 SuperNICs. It provides details as to the interfaces of the board, specifications, required software and firmware for operating the board, and relevant documentation.

Intended Audience

This manual is intended for the installer and user of these cards. The manual assumes basic familiarity with InfiniBand and Ethernet network and architecture specifications.

Ordering Part Numbers

Model	NVIDIA APN	Description	Lifecycle
C9180	900-9X9 1E-00EB -STO	NVIDIA ConnectX-9 C9180 HHHL SuperNIC, Single-cage 800Gbs XDR IB / 800GbE (default), OSFP, PCIe 6 x16 with x16 PCIe SocketDirect Extension option, Crypto Enabled, Secure Boot Enabled, Tall bracket	Prototype
	900-9X9 1E-00EB -DTO	NVIDIA ConnectX-9 C9180 HHHL SuperNIC, Single-cage 800Gbs XDR IB / 800GbE (default), OSFP, PCIe 6 x16 with x16 PCIe Down Stream Port Extension Option, Crypto Enabled, Secure Boot Enabled, Tall bracket	Prototype
C9240	900-9X9 1Q-00C N-STO	NVIDIA ConnectX-9 C9240 HHHL SuperNIC, Dual-port 400GbE (default) / 400Gb/s IB, QSFP112, PCIe 6 x16 with x16 PCIe SocketDirect extension option, Crypto Enabled, Secure Boot Enabled, Tall bracket	Prototype

Technical Support

Customers who purchased NVIDIA products directly from NVIDIA are invited to contact us through the following methods:

- URL: <https://www.nvidia.com> > Support
- E-mail: enterprisesupport@nvidia.com

Customers who purchased NVIDIA Global Support Services, please see your contract for details regarding Technical Support.

Customers who purchased NVIDIA products through an NVIDIA-approved reseller should first seek assistance through their reseller.



Related Documentation

DOCA-Host	User Manual describing DOCA Host features, performance, band diagnostic, tools content and configuration.
DOCA Documentation	User Manual describing DOCA SDK platform development.
WinOF-2 for Windows Documentation	User Manual describing WinOF-2 features, performance, Ethernet diagnostic, tools content and configuration.
MFT User Manual (NVIDIA Firmware Tools)	User Manual describing the set of MFT firmware management tools for a single node.
InfiniBand Specifications	InfiniBand Architecture Specification Release 1.2.1, Vol 2 - Release 1.4, Vol 2 - Release 1.5 and Vol 1 - Release 1.7.
IEEE Ethernet Specifications	IEEE Std 802.3 Specification
PCI-SIG Specifications	Industry Standard PCI Express Base and Card Electromechanical Specifications.
LinkX Interconnect Solutions	LinkX cables and transceivers are designed to maximize the performance of High-Performance Computing networks with exceptional low latency, low power, and reliability for AI and accelerated computing. NVIDIA offers one of the industry's most complete line of 25, 100, 200, 400GbE and 800GbE in Ethernet and EDR, HDR, NDR and XDR including Direct Attach Copper cables (DACs), copper splitter cables, Active Optical Cables (AOCs) and transceivers in a wide range of lengths from 0.5m to 10km. In addition to meeting Ethernet and IBTA standards, NVIDIA tests every product in an end-to-end environment ensuring a Bit Error Rate of less than 1E-15.

When discussing memory sizes, MB and MBytes are used in this document to mean size in MegaBytes. The use of Mb or Mbits (small b) indicates size in MegaBits. IB is used in this document to mean InfiniBand. In this document, PCIe is used to mean PCI Express.

Revision History

A list of the changes made to this document is provided in [Document Revision History](#).

1 Introduction

1.1 Product Overview

The NVIDIA ConnectX®-9 SuperNIC™ is optimized to supercharge hyperscale AI computing workloads. With support for both InfiniBand and Ethernet networking at up to 800 gigabit per second (Gb/s), the ConnectX-9 SuperNIC delivers extremely fast, efficient network connectivity, significantly enhancing system performance for AI factories and cloud data center environments.

Powerful Networking for Generative AI

Central to NVIDIA's AI networking portfolio, ConnectX-9 SuperNICs fuel the next wave of innovation in forming accelerated, massive-scale AI compute fabrics. They seamlessly integrate with next-gen NVIDIA networking platforms, providing end-to-end 800Gb/s connectivity. These platforms offer the robustness, feature sets, and scalability required for trillion-parameter GPU computing, AI data platforms, and agentic AI applications. With enhanced power efficiency, ConnectX-9 SuperNICs support the creation of sustainable AI data centers operating hundreds of thousands of GPUs, ensuring a future-ready infrastructure for AI advancements.

ConnectX-9 SuperNICs enable advanced routing and telemetry-based congestion control capabilities, achieving the highest network performance and peak AI workload efficiency. Additionally, ConnectX-9 InfiniBand SuperNICs extend the capabilities of NVIDIA Scalable Hierarchical Aggregation and Reduction Protocol (SHARP)™ to boost In-Network Computing in high-performance computing environments, further enhancing overall efficiency and performance for both training and inferencing at scale.

1.2 ConnectX-9 Extension Options

There are two available extension options:

1. For 900-9X91E-00EB-ST0 and 900-9X91Q-00CN-ST0: Utilizing the Socket-Direct capability, where the PCIe extension card is connected to the SuperNIC, and is used as an end-point.
2. For 900-9X91E-00EB-DT0: Utilizing the Down Stream Port (DSP) option, where the MCIO connector is used as a root complex for storage devices (GPUs or SSDs).

1.2.1 Socket Direct SuperNICs

The Socket Direct™ technology offers improved performance to dual-socket servers by enabling direct access from each CPU in a dual-socket server to the network through its dedicated PCIe interface. Utilizing the Socket-Direct or the Multi-Host capability, the PCIe extension card is connected to the SuperNIC and is used as an end-point extension.

NVIDIA offers ConnectX-9 Socket Direct, which enables 800Gb/s connectivity for servers with PCIe Gen5 or Gen4 capability, respectively. The SuperNIC's 32-lane PCIe bus is split into two 16-lane buses, with one bus accessible through a PCIe x16 edge connector and the other bus through an x16 Auxiliary PCIe Connection card. The two cards should be installed into two PCIe x16 slots and connected using an MCIO harness.

Please order the additional PCIe Auxiliary Card kit to use the SuperNIC in the Socket-Direct configuration. SuperNICs that support Socket Direct can function as separate x16 PCIe cards.

For more information, please refer to the [PCIe Auxiliary Card Kit](#).

1.2.2 Down Stream Port (DSP)

The ConnectX-9 SuperNIC with downstream port extension option provides connectivity to the server backplane or PCIe switch through the MCIO connector.

The default PCI interface is x4 x 4 to manage four SSD devices.

1.2.3 Port Splitting

ConnectX-9 SuperNICs offer a variety of network port configurations designed to meet the demands of different environments and deployments.

The Port Splitting feature allows a single physical networking module (QSFP112 or OSFP) to be split into multiple network ports. This provides flexibility in optimizing port configurations for various network topology use cases. For the supported OPNs and configurations, refer to [Port Configurations](#).

1.3 System Requirements

Item	Description
PCI Express Slot	<p>In PCIe x16 Configuration PCIe Gen6 @ 64GT/s through x16 edge connector</p> <p>In Socket Direct/Multi-Host Configuration (2x PCIe x16)</p> <ul style="list-style-type: none"> • PCIe Gen6 SERDES @32GT/s through edge connector • PCIe Gen6 SERDES @32GT/s through PCIe Auxiliary Connection Card or SFF-TA-1016 MCIO <p>In PCIe x16 Extension Option - Switch DSP (Data Stream Port)</p> <ul style="list-style-type: none"> • PCIe Gen6 (64GT/s) through x16 edge connector
System Power Supply	Refer to Specifications
Operating System	<ul style="list-style-type: none"> • In-box drivers for major operating systems: <ul style="list-style-type: none"> • Linux: RHEL, Ubuntu • Windows • DOCA Host • OpenFabrics Windows Distribution (WinOF-2)
Connectivity	<ul style="list-style-type: none"> • Interoperable with 25/100/200/400/800 Gb/s Ethernet switches and SDR/EDR/HDR100/HDR/NDR/XDR InfiniBand switches • Passive copper cable with ESD protection • Powered connectors for optical and active cable support

1.4 Package Contents

Category	Qty	Item
Cards	1	ConnectX-9 SuperNIC
Accessories	1	Short bracket

Category	Qty	Item
	1	Tall bracket (shipped assembled on the SuperNIC)

Optional Accessories, not included in the package, can be purchased separately:

OPN	Description
930-9XAX6-0025-000	NVIDIA SocketDirect Auxiliary Kit for Additional PCIe Gen6x16 Connection, 250mm MCIO Harness
930-9XCBL-000A-000	NVIDIA SuperNIC 200mm Cable Extender for Low-Speed Signals Over 30p Debug Connector

1.5 Features and Benefits

⚠ Make sure to use a PCIe slot capable of supplying the required power and airflow to the ConnectX-9 SuperNICs as stated in the [Specifications](#) chapter.

⚠ This section describes hardware features and capabilities. Please refer to the relevant driver and firmware release notes for feature availability.

PCI Express (PCIe)	<p>According to the OPN you have purchased, the card uses the following PCIe express interfaces:</p> <ul style="list-style-type: none"> • PCIe x16 configurations: PCIe Gen6 (64GT/s) through x16 edge connector • 2x PCIe x16 configurations (Socket-Direct): PCIe Gen6 (SERDES @ 64GT/s / 32GT/s) through x16 edge connector PCIe Gen6 SERDES @ 32GT/s through PCIe Auxiliary Connection Card • 2x PCIe x16 configurations (PCIe Down Stream Port Extension Option): PCIe Gen6 (SERDES @ 64GT/s / 32GT/s) through x16 edge connector 																																																						
InfiniBand Architecture Specification v1.7 compliant	<p>ConnectX-9 delivers low latency, high bandwidth, and computing efficiency for high-performance computing (HPC), artificial intelligence (AI), and hyperscale cloud data center applications. ConnectX-9 is InfiniBand Architecture Specification v1.7 compliant.</p> <p>InfiniBand Network Protocols and Rates</p> <p>C9180 SuperNICs</p> <table border="1" data-bbox="421 1048 1391 1391"> <thead> <tr> <th rowspan="2">Protocol</th> <th rowspan="2">Standard</th> <th colspan="3">Port Width Rate (Gb/s)</th> <th rowspan="2">Encoding</th> </tr> <tr> <th>4x (4 lane) Port</th> <th>2x (2 lane) Port</th> <th>1x (1 lane) Port</th> </tr> </thead> <tbody> <tr> <td>XDR</td> <td>IBTA Vol1 1.7</td> <td>--</td> <td>425</td> <td>212.5</td> <td>PAM4</td> </tr> <tr> <td>NDR</td> <td>IBTA Vol2 1.5</td> <td>425</td> <td>212.5</td> <td>--</td> <td>PAM4</td> </tr> <tr> <td>HDR</td> <td>IBTA Vol2 1.4</td> <td>212.5</td> <td>106.25</td> <td>53.125</td> <td>PAM4</td> </tr> </tbody> </table> <p>C9240 SuperNICs</p> <table border="1" data-bbox="421 1458 1391 1800"> <thead> <tr> <th rowspan="2">Protocol</th> <th rowspan="2">Standard</th> <th colspan="3">Port Width Rate (Gb/s)</th> <th rowspan="2">Encoding</th> </tr> <tr> <th>4x (4 lane) Port</th> <th>2x (2 lane) Port</th> <th>1x (1 lane) Port</th> </tr> </thead> <tbody> <tr> <td>XDR</td> <td>IBTA Vol1 1.7</td> <td>--</td> <td>425</td> <td>212.5</td> <td>PAM4</td> </tr> <tr> <td>NDR</td> <td>IBTA Vol2 1.5</td> <td>425</td> <td>212.5</td> <td>--</td> <td>PAM4</td> </tr> <tr> <td>HDR</td> <td>IBTA Vol2 1.4</td> <td>212.5</td> <td>106.25</td> <td>53.125</td> <td>PAM4</td> </tr> </tbody> </table> <p>With these basic rates, 800Gb/s can be built from 4 ports of 200Gb/s, for example.</p>	Protocol	Standard	Port Width Rate (Gb/s)			Encoding	4x (4 lane) Port	2x (2 lane) Port	1x (1 lane) Port	XDR	IBTA Vol1 1.7	--	425	212.5	PAM4	NDR	IBTA Vol2 1.5	425	212.5	--	PAM4	HDR	IBTA Vol2 1.4	212.5	106.25	53.125	PAM4	Protocol	Standard	Port Width Rate (Gb/s)			Encoding	4x (4 lane) Port	2x (2 lane) Port	1x (1 lane) Port	XDR	IBTA Vol1 1.7	--	425	212.5	PAM4	NDR	IBTA Vol2 1.5	425	212.5	--	PAM4	HDR	IBTA Vol2 1.4	212.5	106.25	53.125	PAM4
Protocol	Standard			Port Width Rate (Gb/s)				Encoding																																															
		4x (4 lane) Port	2x (2 lane) Port	1x (1 lane) Port																																																			
XDR	IBTA Vol1 1.7	--	425	212.5	PAM4																																																		
NDR	IBTA Vol2 1.5	425	212.5	--	PAM4																																																		
HDR	IBTA Vol2 1.4	212.5	106.25	53.125	PAM4																																																		
Protocol	Standard	Port Width Rate (Gb/s)			Encoding																																																		
		4x (4 lane) Port	2x (2 lane) Port	1x (1 lane) Port																																																			
XDR	IBTA Vol1 1.7	--	425	212.5	PAM4																																																		
NDR	IBTA Vol2 1.5	425	212.5	--	PAM4																																																		
HDR	IBTA Vol2 1.4	212.5	106.25	53.125	PAM4																																																		

Up to 800 Gigabit Ethernet	ConnectX-9 SuperNICs comply with the following IEEE 802.3 standards: 800GbE / 400GbE / 200GbE / 100GbE / 25GbE / 10GbE																				
	<table border="1"> <thead> <tr> <th>Protocol</th> <th>Ethernet Network Rate</th> </tr> </thead> <tbody> <tr> <td>IEEE 802.3dj <ul style="list-style-type: none"> • Clause 179 • Annex 176D </td> <td>800/400/200 Gigabit Ethernet</td> </tr> <tr> <td>IEEE 802.3df <ul style="list-style-type: none"> • Clause 162 • Annex 120G </td> <td>800/400/200/100 Gigabit Ethernet</td> </tr> <tr> <td>IEEE 802.3-2022 <ul style="list-style-type: none"> • Clause 136 • Annex 120E • Annex 135F Ethernet Technology Consortium </td> <td>50/100/200/400Gb/s Gigabit Ethernet</td> </tr> <tr> <td>IEEE 802.3-2022 <ul style="list-style-type: none"> • Clause 110 • Annex 109B </td> <td>25 Gigabit Ethernet</td> </tr> <tr> <td>IEEE 802.3-2022 <ul style="list-style-type: none"> • Clause 73 </td> <td>Auto-negotiation</td> </tr> <tr> <td>IEEE 802.3-2022 <ul style="list-style-type: none"> • Section 136.8.11 IEEE 802.3df <ul style="list-style-type: none"> • Section 162.8.11 IEEE 802.3dj <ul style="list-style-type: none"> • Annex 178B </td> <td>Link training</td> </tr> <tr> <td>IEEE 802.1AX</td> <td>Link Aggregation</td> </tr> <tr> <td>IEEE 802.1Q IEEE 802.1P VLAN tags and priority</td> <td></td> </tr> <tr> <td>IEEE 802.1Qau (QCN) Congestion Notification IEEE 802.1Qaz (ETS) IEEE 802.1Qbb (PFC) IEEE 802.1Qbg IEEE 1588v2 Jumbo frame support (9.6KB)</td> <td></td> </tr> </tbody> </table>	Protocol	Ethernet Network Rate	IEEE 802.3dj <ul style="list-style-type: none"> • Clause 179 • Annex 176D 	800/400/200 Gigabit Ethernet	IEEE 802.3df <ul style="list-style-type: none"> • Clause 162 • Annex 120G 	800/400/200/100 Gigabit Ethernet	IEEE 802.3-2022 <ul style="list-style-type: none"> • Clause 136 • Annex 120E • Annex 135F Ethernet Technology Consortium	50/100/200/400Gb/s Gigabit Ethernet	IEEE 802.3-2022 <ul style="list-style-type: none"> • Clause 110 • Annex 109B 	25 Gigabit Ethernet	IEEE 802.3-2022 <ul style="list-style-type: none"> • Clause 73 	Auto-negotiation	IEEE 802.3-2022 <ul style="list-style-type: none"> • Section 136.8.11 IEEE 802.3df <ul style="list-style-type: none"> • Section 162.8.11 IEEE 802.3dj <ul style="list-style-type: none"> • Annex 178B 	Link training	IEEE 802.1AX	Link Aggregation	IEEE 802.1Q IEEE 802.1P VLAN tags and priority		IEEE 802.1Qau (QCN) Congestion Notification IEEE 802.1Qaz (ETS) IEEE 802.1Qbb (PFC) IEEE 802.1Qbg IEEE 1588v2 Jumbo frame support (9.6KB)	
	Protocol	Ethernet Network Rate																			
	IEEE 802.3dj <ul style="list-style-type: none"> • Clause 179 • Annex 176D 	800/400/200 Gigabit Ethernet																			
	IEEE 802.3df <ul style="list-style-type: none"> • Clause 162 • Annex 120G 	800/400/200/100 Gigabit Ethernet																			
	IEEE 802.3-2022 <ul style="list-style-type: none"> • Clause 136 • Annex 120E • Annex 135F Ethernet Technology Consortium	50/100/200/400Gb/s Gigabit Ethernet																			
	IEEE 802.3-2022 <ul style="list-style-type: none"> • Clause 110 • Annex 109B 	25 Gigabit Ethernet																			
	IEEE 802.3-2022 <ul style="list-style-type: none"> • Clause 73 	Auto-negotiation																			
	IEEE 802.3-2022 <ul style="list-style-type: none"> • Section 136.8.11 IEEE 802.3df <ul style="list-style-type: none"> • Section 162.8.11 IEEE 802.3dj <ul style="list-style-type: none"> • Annex 178B 	Link training																			
	IEEE 802.1AX	Link Aggregation																			
IEEE 802.1Q IEEE 802.1P VLAN tags and priority																					
IEEE 802.1Qau (QCN) Congestion Notification IEEE 802.1Qaz (ETS) IEEE 802.1Qbb (PFC) IEEE 802.1Qbg IEEE 1588v2 Jumbo frame support (9.6KB)																					
Memory Components	<ul style="list-style-type: none"> • SPI - includes 512Mbit SPI Quad Flash device. • FRU EEPROM - Stores the parameters and personality of the SuperNIC. The EEPROM capacity is 128Kbit. FRU I2C address is (0x50) and is accessible through the PCIe SMBus. (Note: Address 0x58 is reserved.) 																				
Overlay Networks	In order to better scale their networks, data center operators often create overlay networks that carry traffic from individual virtual machines over logical tunnels in encapsulated formats such as NVGRE and VXLAN. While this solves network scalability issues, it hides the TCP packet from the hardware offloading engines, placing higher loads on the host CPU. ConnectX-9 effectively addresses this by providing advanced NVGRE and VXLAN hardware offloading engines that encapsulate and de-capsulate the overlay protocol.																				
Quality of Service (QoS)	Support for port-based Quality of Service enabling various application requirements for latency and SLA.																				

Hardware-based I/O Virtualization	ConnectX-9 provides dedicated adapter resources and guaranteed isolation and protection for virtual machines within the server.
SR-IOV	ConnectX-9 SR-IOV technology provides dedicated adapter resources and guaranteed isolation and protection for virtual machines (VM) within the server.
High-Performance Accelerations	<ul style="list-style-type: none"> • Vector collective operations offload • MPI_Alltoall offloads • Rendezvous protocol offload
Secure Boot	The secure boot process assures the booting of authentic firmware/software that is intended to run on ConnectX-9. This is achieved using a hybrid approach consisting of both post-quantum and traditional cryptography. ConnectX-9 supports several cryptographic functions in its HW Root-of-Trust (RoT) that has its key stored in on-chip fuses.
Secure Firmware Update	The Secure firmware update feature enables a device to verify digital signatures of new firmware binaries using a hybrid approach consisting of both post-quantum and traditional cryptography to ensure that only officially approved versions can be installed from the host, the network, or a Board Management Controller (BMC). The firmware of devices with “secure firmware update” functionality (secure FW), restricts access to specific commands and registers that can be used to modify the firmware binary image on the flash, as well as commands that can jeopardize security in general. For further information, refer to the MFT User Manual .
Host Management	<p>ConnectX-9 technology maintains support for host manageability through a BMC. ConnectX-9 PCIe stand-up adapter can be connected to a BMC using MCTP over SMBus or MCTP over PCIe protocols as if it is a standard NVIDIA PCIe stand-up SuperNIC. For configuring the adapter for the specific manageability solution in use by the server, please contact NVIDIA Support.</p> <ul style="list-style-type: none"> • Protocols: PLDM, NCSI • Transport layer - RBT, MCTP over SMBus, and MCTP over PCIe • Physical layer: SMBus 2.0 / I2C interface for device control and configuration, PCIe • PLDM for Monitor and Control DSP0248 • PLDM for Firmware Update DSP026 • IEEE 1149.6 • Secured FW update • FW Recovery • NIC reset • Monitoring and control • Network port settings • Boot setting
RDMA and RDMA over Converged Ethernet (RoCE)	ConnectX-9, utilizing IBTA RDMA (Remote Data Memory Access) and RoCE (RDMA over Converged Ethernet) technology, delivers low latency and high-performance over InfiniBand and Ethernet networks. Leveraging datacenter bridging (DCB) capabilities as well as ConnectX-9 advanced congestion control hardware mechanisms, RoCE provides efficient low-latency RDMA services over Layer 2 and Layer 3 networks.
NVIDIA PeerDirect™	PeerDirect™ communication provides high-efficiency RDMA access by eliminating unnecessary internal data copies between components on the PCIe bus (for example, from GPU to CPU), and therefore significantly reduces application run time. ConnectX-9 advanced acceleration technology enables higher cluster efficiency and scalability to tens of thousands of nodes.
CPU Offload	<p>Adapter functionality enables reduced CPU overhead allowing more available CPU for computation tasks.</p> <ul style="list-style-type: none"> • Flexible match-action flow tables • Open VSwitch (OVS) offload using ASAP2® • Tunneling encapsulation/decapsulation

Cryptography Accelerations	ConnectX-9 supports IPsec, and PSP cryptography acceleration. ConnectX-9 SuperNIC hardware-based accelerations offload the crypto operations and free up the CPU, reducing latency and enabling scalable crypto solutions.
Advanced AI / HPC Networking	<ul style="list-style-type: none"> • RDMA and RoCEv2 accelerations • Advanced, programmable congestion control • NVIDIA GPUDirect® RDMA • GPUDirect Storage • In-Network Computing • High-speed packet reordering • MPI accelerations • Burst-buffer offloads • Collective operations • Enhanced atomic operations • Rendezvous protocol offloads

2 Supported Interfaces

This section describes the ConnectX-9 SuperNIC supported interfaces. Each numbered interface referenced in the figures is described in the following table with a link to detailed information.

⚠ The below figures are for illustration purposes only and might not reflect the current revision of the SuperNIC.

2.1 ConnectX-9 Layout and Interface Information

ConnectX-9 Model	Front View	Back View
C9180 SuperNICs <ul style="list-style-type: none"> • 900-9X91E-00EB-STO • 900-9X91E-00EB-DTO 		
C9240 SuperNIC <ul style="list-style-type: none"> • 900-9X91Q-00CN-STO 		

Item	Interface	Description
	ConnectX-9 IC	ConnectX-9 Integrated Circuit
1	Host Interface	PCIe Gen6 through x16 edge connector
2	Networking Interfaces	Network traffic is transmitted through the networking connectors. The networking connectors allow for the use of modules, optical and passive cable interconnect solutions
3	Networking Ports LEDs	Two I/O LEDs per port to indicate speed and link status
4	MCIO Connector	One MCIO connector is populated to allow connectivity to an additional PCIe x16 interface
5	Sideband Management Interface	Allows for BMC connectivity for remote management

2.2 Interfaces Detailed Description

2.2.1 ConnectX-9 IC

The ConnectX-9 family of IC devices delivers InfiniBand and Ethernet connectivity paired with best-in-class hardware capabilities that accelerate and secure cloud and data-center workloads.

2.2.2 Host Interface

ConnectX-9 SuperNIC supports PCI Express Gen6 (5.0 and 4.0 compatible) through an x16 edge connector. The following lists host interface features:

- PCIe Gen6 or Gen5 (up to x32 PCIe lanes)
- NVIDIA Multi-Host™ (up to 4 hosts)
- PCIe switch downstream port containment (DPC) - Applies to 900-9X91E-00EB-DT0 only
- MSI/MSI-X

2.2.3 Networking Interfaces

⚠ The SuperNIC includes special circuits to protect the SuperNIC/server from ESD shocks when plugging copper cables.

Ethernet and InfiniBand traffic is transmitted through the networking connectors (QSFP112 or OSFP) on the SuperNIC.

Protocol	Specifications
Ethernet	The network ports comply with the IEEE 802.3 Ethernet standards in Features and Benefits .
InfiniBand	The network ports are compliant with the InfiniBand Architecture Specification, Release 1.7 .

2.2.4 Networking Ports LEDs Specifications

For the description of the networking ports LEDs, follow the table below, depending on the ConnectX-8 SuperNIC you have purchased.

SKU	LEDs Scheme
C9240 SuperNICs • 900-9X91Q-00CN-ST0	Scheme 1: One Bi-Color LED
C9180 SuperNICs • 900-9X91E-00EB-ST0 • 900-9X91E-00EB-DT0	Scheme 2: Two LEDs

2.2.4.1 Scheme 1: One Bi-Color LED

There is one bi-color (Yellow and Green) I/O LED per port that indicate port speed and link status.

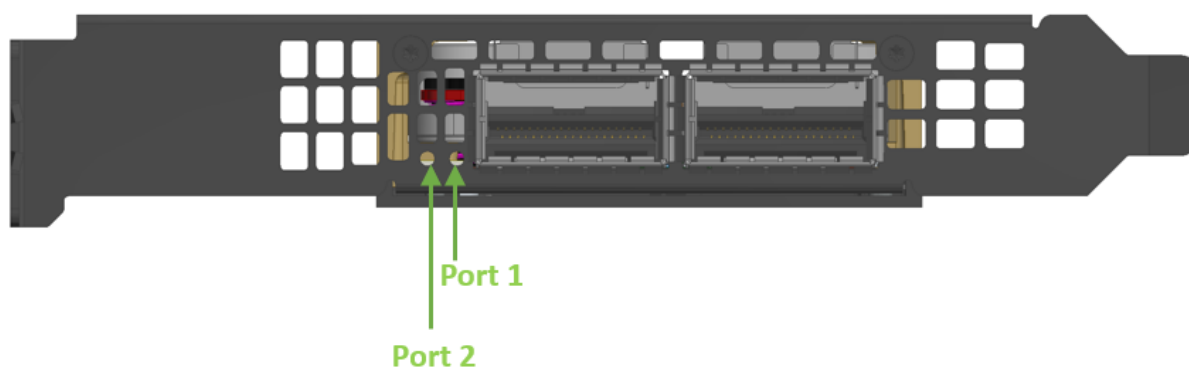

State	Bi-Color LED (Yellow/Green)
Beacon command for locating the SuperNIC	1Hz blinking Yellow

State	Bi-Color LED (Yellow/Green)		
Error	4Hz blinking Yellow Indicates an error with the link. The error can be one of the following:		
	Error Type	Description	LED Behavior
	I ² C	I ² C access to the networking ports fails	Blinks until the error is fixed
Over-current	Over-current condition of the networking ports	Blinks until the error is fixed	
Physical Activity	The Green LED will blink.		
Link Up	The Green LED will be solid.		
Physical Up (IB Only)	The Yellow LED will be solid.		

2.2.4.2 Scheme 2: Two LEDs

There are two I/O LEDs per port that indicate port speed and link status.

- LED1 is a bi-color LED (Yellow and Green)
- LED2 is a single-color LED (Green)

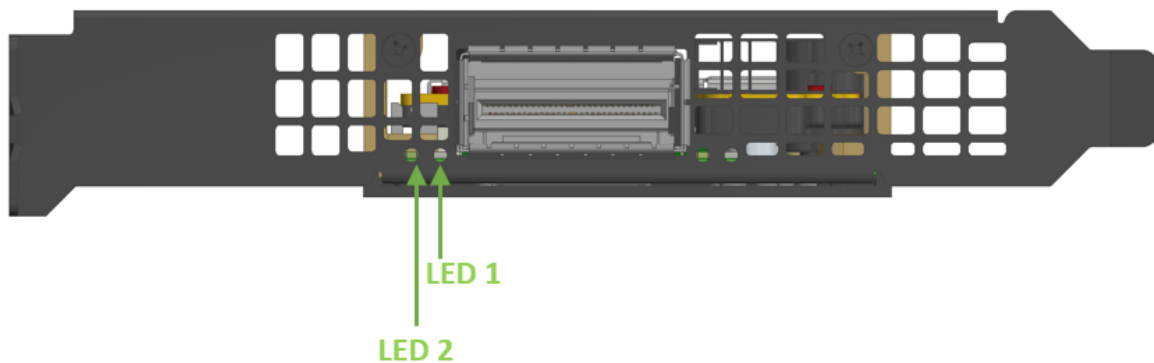

State	Bi-Color LED (Yellow/Green)	Single Color LED (Green)	
Beacon command for locating the SuperNIC	1Hz blinking Yellow	OFF	
Error	4Hz blinking Yellow Indicates an error with the link. The error can be one of the following:		
	Error Type	Description	LED Behavior
	i ² C	i ² C access to the networking ports fails	Blinks until the error is fixed
	Over-current	Over-current condition of the networking ports	Blinks until the error is fixed
Physical Activity	In full port speed: the Green LED is solid In less than full port speed: the Yellow LED is solid	Blinking	
Link Up	In full port speed: the Green LED is solid In less than full port speed: the Yellow LED is solid	ON	
Physical Up (IB Only)	The Yellow LED will be solid.	OFF	

2.2.5 MCIO Connector

The MCIO (Multi-Channel I/O) connector in ConnectX-9 SuperNICs is a high-speed interface that provides efficient, scalable, and flexible connectivity for various data center applications. This connector supports multiple lanes of high-bandwidth data transfer, enabling faster and more efficient communication between the network card and the system or other connected components.

The 124 pins MCIO connector (SFF-TA-1016 by Amphenol) allows connectivity to an additional PCIe x16 interface or DSP devices (NVMe SSDs) via the MCIO cable. For pinouts, refer to the [MCIO Interface](#).

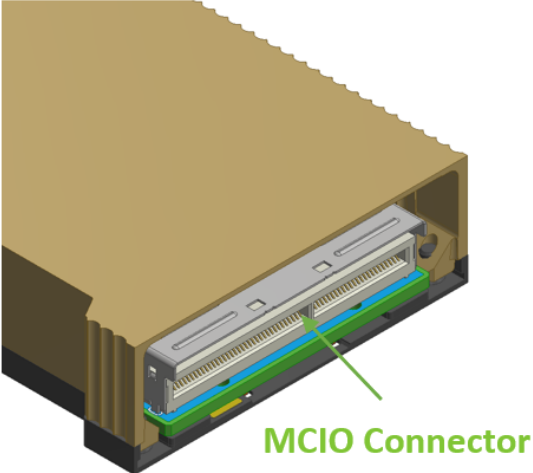

2.2.6 Sideband Management Interface

The sideband management interface in ConnectX-9 SuperNICs enhances remote manageability, diagnostics, and maintenance capabilities, critical for high-availability environments like data centers and cloud infrastructure.

The sideband management interface (a 30-pin IPEX connector) in ConnectX-9 SuperNICs enables out-of-band management, allowing administrators to monitor and control the network device independently of regular data traffic. It supports remote monitoring, even when the host system is unresponsive, by integrating with Baseboard Management Controllers (BMC) for tasks like firmware updates, diagnostics, and health monitoring. This interface ensures continuous management of the NIC's performance, security, and status without disrupting network operations, making it vital for maintaining uptime in data centers and cloud environments.

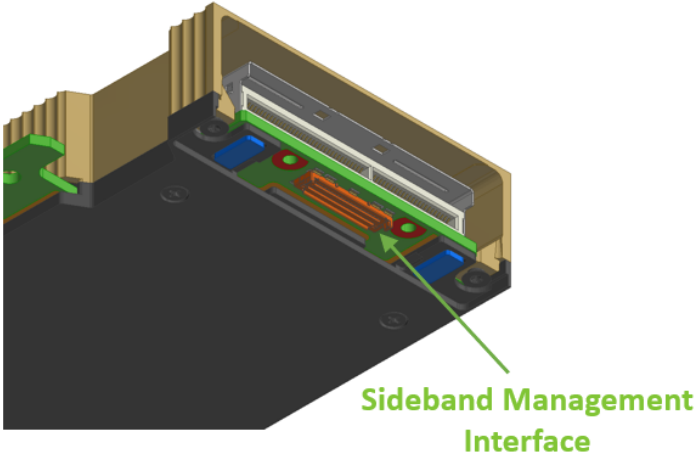

The table below specifies the maximum trace lengths per board type. Please consider the maximum trace length on the board in your design.

SKUs	Maximum Trace Length on the Board
C9240 SuperNICs <ul style="list-style-type: none"> 900-9X91Q-00CN-ST0 	140mm (5.51 inch)
C9180 SuperNICs <ul style="list-style-type: none"> 900-9X91E-00EB-ST0 900-9X91E-00EB-DT0 	75mm (2.95 inch)

2.2.6.1 ConnectX-9 Cable Extender Debugging Kit

An optional accessory is available for debugging purposes. The ConnectX-9 Cable Extender board provides access to the MTUSB, PPS, NCSI, EN_INB_REC, and FNP interfaces, enabling debugging.

The kit includes the extender board and a 200mm IPEX cable (micro-coax, pin-to-pin, lock-to-lock) that can be connected via the 30-pin connector on the ConnectX-9 SuperNIC.

OPN	Description
930-9XCBL-000A-000	NVIDIA SuperNIC 200mm Cable Extender for Low-Speed Signals Over 30p Debug Connector

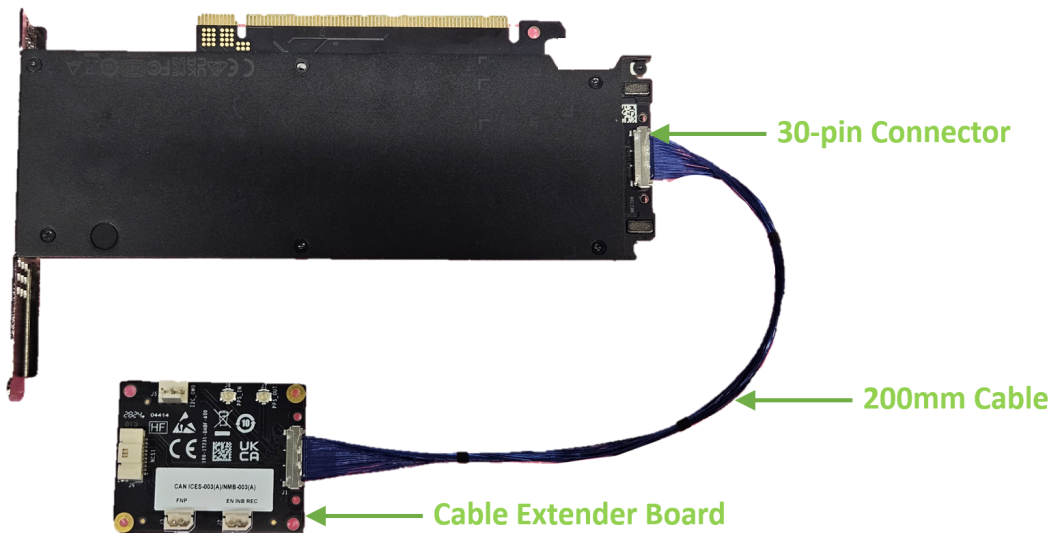

2.3 Pinouts Description

2.3.1 NC-SI Sideband Interface

The following table lists the NC-SI management interface pinout descriptions. For further details, please refer to [NC-SI Sideband Interface](#).

Pin Name	Pin Description
GND	Ground

Pin Name	Pin Description
RBT_RDX0	Receive data. Data signals from the network controller to the BMC.
RBT_RDX1	
RBT_CRSDV	Carrier sense/receive data validly
GND	Ground
RBT_TX0	Transmit data. Data signals from the BMC to the network controller
RBT_TX1	
RBT_TX_EN	Transmit enable
RBT_REF_CLK	RBT Reference clock
GND	Ground
ARB_OUT	NC-SI hardware arbitration output
ARB_IN	NC-SI hardware arbitration input
GND	Ground
I2C_CLK0	I2C clock (Debug)
I2C_SDA0	I2C Data (Debug)
PKG_ID0	NC-SI PKG_ID [0]
PKG_ID1	NC-SI PKG_ID [1]
RBT_ISOLATE_N	The signal used to indicate the board has powered and is ready for the NC-SI physical layer connection to be present
FNFP	ConnectX Flash is NOT present
enable_inband_recovery	PCIe operatiin live fish mode
PPS IN	PPS input for timing applications
PPS OUT	PPS output for timing applications
RSVD3	Reserved
RSVD4	Reserved
RSVD5	Reserved
RSVD6	Reserved
RSVD7	Reserved
RSVD8	Reserved
RSVD9	Reserved
RSVD10	Reserved

2.3.2 MCIO Interface

The tables below list the MCIO connector pinout descriptions, per SuperNIC OPN. For further details, please refer to [MCIO Connector](#).

2.3.2.1 Default (Socket-Direct/Multi-Host) Pinouts for 900-9X91E-00EB-ST0 and 900-9X91Q-00CN-ST0 SuperNICs

Additional Electrical Information	Description/Direction	Pin	Pin	Description/Direction	Additional Electrical Information
	GND	A1	B1	GND	
	PERp0	A2	B2	PETp0	
	PERn0	A3	B3	PETn0	
	GND	A4	B4	GND	
	PERp1	A5	B5	PETp1	
	PERn1	A6	B6	PETn1	
	GND	A7	B7	GND	
Logic: Open-drain Voltage Level: 3.3V Presence of PU/PD: PU 100k ohm	SMBUS_SCL (IN)	A8	B8	3V3_AUX (IN)	Logic: Same power requirements as 3V3_AUX in PCIe spec Voltage Level: 3.3V
Logic: Open-drain Voltage Level: 3.3V Presence of PU/PD: PU 100k ohm	SMBUS_SDA (BID)	A9	B9	FLEXIO0_A	Presence of PU/PD: PD termination 42.2 ohm
	GND	A10	B10	GND	
Logic: Push-pull, active low Voltage Level: 3.3V	PERST_A_N (IN)	A11	B11	REFCLK_A_Dp (IN)	Logic: PCIe REFCLK IN
Logic: Active low Voltage Level: 3.3V Presence of PU/PD: PD 200 ohm Recommended implementation on System level: PU 100k ohm	CBL_PRES_A (OUT)	A12	B12	REFCLK_A_Dn (IN)	Logic: PCIe REFCLK IN
	GND	A13	B13	GND	
	PERp2	A14	B14	PETp2	
	PERn2	A15	B15	PETn2	
	GND	A16	B16	GND	
	PERp3	A17	B17	PETp3	

	PERn3	A1 8	B1 8	PETn3	
	GND	A1 9	B1 9	GND	
	PERp4	A2 0	B2 0	PETp4	
	PERn4	A2 1	B2 1	PETn4	
	GND	A2 2	B2 2	GND	
	PERp5	A2 3	B2 3	PETp5	
	PERn5	A2 4	B2 4	PETn5	
	GND	A2 5	B2 5	GND	
Presence of PU/PD: PD termination 42.2 ohm	FLEXIO3_A/ I2C_M_SDA_A (NC)	A2 6	B2 6	FLEXIO1_A/ REFCLK_B_Dp	Presence of PU/PD: PD termination 42.2 ohm
Presence of PU/PD: PD termination 42.2 ohm	FLEXIO4_A/ I2C_M_SCL_A (NC)	A2 7	B2 7	FLEXIO2_A/ REFCLK_B_Dn	Presence of PU/PD: PD termination 42.2 ohm
	GND	A2 8	B2 8	GND	
Presence of PU/PD: PD termination 42.2 ohm	PERST_B_N (IN)	A2 9	B2 9	FLEXIO7_A	Presence of PU/PD: PD termination 42.2 ohm
Presence of PU/PD: PD termination 42.2 ohm	CBL_PRES_B (OUT)	A3 0	B3 0	FLEXIO8_A	Presence of PU/PD: PD termination 42.2 ohm
	GND	A3 1	B3 1	GND	
	PERp6	A3 2	B3 2	PETp6	
	PERn6	A3 3	B3 3	PETn6	
	GND	A3 4	B3 4	GND	
	PERp7	A3 5	B3 5	PETp7	
	PERn7	A3 6	B3 6	PETn7	

	GND	A3 7	B3 7	GND	
	Key				
	GND	A3 8	B3 8	GND	
	PERp8	A3 9	B3 9	PETp8	
	PERn8	A4 0	B4 0	PETn8	
	GND	A4 1	B4 1	GND	
	PERp9	A4 2	B4 2	PETp9	
	PERn9	A4 3	B4 3	PETn9	
	GND	A4 4	B4 4	GND	
	PERp10	A4 5	B4 5	PETp10	
	PERn10	A4 6	B4 6	PETn10	
	GND	A4 7	B4 7	GND	
	PERp11	A4 8	B4 8	PETp11	
	PERn11	A4 9	B4 9	PETn11	
	GND	A5 0	B5 0	GND	
	PERp12	A5 1	B5 1	PETp12	
	PERn12	A5 2	B5 2	PETn12	
	GND	A5 3	B5 3	GND	
	PERp13	A5 4	B5 4	PETp13	
	PERn13	A5 5	B5 5	PETn13	

	GND	A5 6	B5 6	GND	
	PERp14	A5 7	B5 7	PETp14	
	PERn14	A5 8	B5 8	PETn14	
	GND	A5 9	B5 9	GND	
	PERp15	A6 0	B6 0	PETp15	
	PERn15	A6 1	B6 1	PETn15	
	GND	A6 2	B6 2	GND	

2.3.2.2 Switch Mode Pinouts for 900-9X91E-00EB-DT0 SuperNICs

Additional Electrical Information	Direction	Description/Direction	Pin	Pin	Description/Direction	Additional Electrical Information
		GND	A 1	B 1	GND	
		PERp0	A 2	B 2	PETp0	
		PERn0	A 3	B 3	PETn0	
		GND	A 4	B 4	GND	
		PERp1	A 5	B 5	PETp1	
		PERn1	A 6	B 6	PETn1	
		GND	A 7	B 7	GND	
Logic: Same power requirements as 3V3_AUX in PCIe spec Voltage Level: 3.3V	OUT	3V3_AUX (OUT)	A 8	B 8	SMBUS_SCL_A (OUT)	Logic: Open-drain Voltage Level: 3.3V Presence of PU/PD: PU 45.3k ohm
Logic: Open-drain Voltage Level: 3.3V Recommended implementation on System level: PU resistor	IN	VPP_INT_N (IN)	A 9	B 9	SMBUS_SDA_A (BID)	Logic: Open-drain Voltage Level: 3.3V Presence of PU/PD: PU 45.3k ohm

		GND	A 10	B 10	GND	
Logic: PCIe REFCLK OUT	OUT	REFCLK_A_Dp (OUT)	A 11	B 11	PERST_A_N (OUT)	Logic: Push-pull, active low Voltage Level: 3.3V
Logic: PCIe REFCLK OUT	OUT	REFCLK_A_Dn (OUT)	A 12	B 12	CBL_PRES_A (IN)	Logic: Active low Voltage Level: 3.3V Presence of PU/PD: PU 45.3k ohm PD 200 ohm
		GND	A 13	B 13	GND	
		PERp2	A 14	B 14	PETp2	
		PERn2	A 15	B 15	PETn2	
		GND	A 16	B 16	GND	
		PERp3	A 17	B 17	PETp3	
		PERn3	A 18	B 18	PETn3	
		GND	A 19	B 19	GND	
		PERp4	A 20	B 20	PETp4	
		PERn4	A 21	B 21	PETn4	
		GND	A 22	B 22	GND	
		PERp5	A 23	B 23	PETp5	
		PERn5	A 24	B 24	PETn5	
		GND	A 25	B 25	GND	
Logic: Open-drain Voltage Level: 3.3V Presence of PU/PD: PU 1.5k ohm	BID	VPP_SDA_A	A 26	B 26	FLEXIO3_A / PWRBRK/ SER_CLK(NC)	Presence of PU/PD: PD termination 42.2 ohm
Logic: Open-drain Voltage Level: 3.3V Presence of PU/PD: PU 1.5k ohm	OUT	VPP_SCL_A	A 27	B 27	FLEXIO4_A / WAKE/ SER_CAPTURE(N C)	Presence of PU/PD: PD termination 42.2 ohm

		GND	A 28	B 28	GND	
Presence of PU/PD: PD termination 42.2 ohm		FLEXIO7_A/ USB2_A_Dp / SER_DO(NC)	A 29	B 29	PERST_B_N	Presence of PU/PD: PD termination 42.2 ohm
Presence of PU/PD: PD termination 42.2 ohm		FLEXIO8_A/ USB2_A_Dn/ SER_DI(NC)	A 30	B 30	CBL_PRES_B	Presence of PU/PD: PD termination 42.2 ohm
		GND	A 31	B 31	GND	
		PERp6	A 32	B 32	PETp6	
		PERn6	A 33	B 33	PETn6	
		GND	A 34	B 34	GND	
		PERp7	A 35	B 35	PETp7	
		PERn7	A 36	B 36	PETn7	
		GND	A 37	B 37	GND	
		Key				
		GND	A 38	B 38	GND	
		PERp8	A 39	B 39	PETp8	
		PERn8	A 40	B 40	PETn8	
		GND	A 41	B 41	GND	
		PERp9	A 42	B 42	PETp9	
		PERn9	A 43	B 43	PETn9	
		GND	A 44	B 44	GND	
		PERp10	A 45	B 45	PETp10	
		PERn10	A 46	B 46	PETn10	

		GND	A 47	B 47	GND	
		PERp11	A 48	B 48	PETp11	
		PERn11	A 49	B 49	PETn11	
		GND	A 50	B 50	GND	
		PERp12	A 51	B 51	PETp12	
		PERn12	A 52	B 52	PETn12	
		GND	A 53	B 53	GND	
		PERp13	A 54	B 54	PETp13	
		PERn13	A 55	B 55	PETn13	
		GND	A 56	B 56	GND	
		PERp14	A 57	B 57	PETp14	
		PERn14	A 58	B 58	PETn14	
		GND	A 59	B 59	GND	
		PERp15	A 60	B 60	PETp15	
		PERn15	A 61	B 61	PETn15	
		GND	A 62	B 62	GND	

3 Hardware Installation

Installation and initialization of ConnectX-9 SuperNIC require attention to the mechanical attributes, power specification, and precautions for electronic equipment.

3.1 Safety Warnings



Safety warnings are provided here in the English language. For safety warnings in other languages, refer to the [SuperNIC Installation Safety Instructions](#).

Please observe all safety warnings to avoid injury and prevent damage to system components. Note that not all warnings are relevant to all models.

Note that not all warnings are relevant to all models.

	General Installation Instructions Read all installation instructions before connecting the equipment to the power source.
	Jewelry Removal Warning Before you install or remove equipment that is connected to power lines, remove jewelry such as bracelets, necklaces, rings, watches, and so on. Metal objects heat up when connected to power and ground and can meltdown, causing serious burns and/or welding the metal object to the terminals.
	Over-temperature This equipment should not be operated in an area with an ambient temperature exceeding the maximum recommended: 55°C (131°F). An airflow of 200LFM at this maximum ambient temperature is required for HCA cards and NICs. To guarantee proper airflow, allow at least 8cm (3 inches) of clearance around the ventilation openings.
	During Lightning - Electrical Hazard During periods of lightning activity, do not work on the equipment or connect or disconnect cables.
	Copper Cable Connecting/Disconnecting Some copper cables are heavy and not flexible, as such, they should be carefully attached to or detached from the connectors. Refer to the cable manufacturer for special warnings and instructions.
	Equipment Installation This equipment should be installed, replaced, or serviced only by trained and qualified personnel.
	Equipment Disposal The disposal of this equipment should be in accordance to all national laws and regulations.
	Local and National Electrical Codes This equipment should be installed in compliance with local and national electrical codes.
	Hazardous Radiation Exposure <ul style="list-style-type: none">• Caution - Use of controls or adjustment or performance of procedures other than those specified herein may result in hazardous radiation exposure. For products with optical ports.• CLASS 1 LASER PRODUCT and reference to the most recent laser standards: IEC 60 825-1:1993 + A1:1997 + A2:2001 and EN 60825-1:1994+A1:1996+ A2:20

3.2 Installation Procedure Overview

The installation procedure of ConnectX-9 SuperNICs involves the following steps:

Step	Procedure	Direct Link
1	Check the system's requirements.	System Requirements
2	Follow the safety precautions	Safety Precautions
3	Unpack the package	Unpack the package
5	Follow the pre-installation checklist	Pre-Installation Checklist
6	(Optional) Replace the full-height mounting bracket with the supplied short bracket	Bracket Replacement Instructions
7	Install the ConnectX-9 PCIe x16 SuperNIC in the chassis	ConnectX-9 PCIe x16 Installation Instructions
	(Optional) Install the ConnectX-9 Extension Option (2x PCIe x16) in the chassis	ConnectX-9 Extension Option (2x PCIe x16) Installation Instructions
8	Connect cables or modules to the cards	Cables and Modules
9	Identify the SuperNIC in the system	Identifying Your SuperNIC

3.3 System Requirements

To successfully integrate the ConnectX-9 SuperNIC into a chassis, ensure that the following system requirements are met:



Unless otherwise specified, NVIDIA products are designed to work in an environmentally controlled data center with low levels of gaseous and dust (particulate) contamination. The operating environment should meet severity level G1 as per ISA 71.04 for gaseous contamination and ISO 14644-1 class 8 for cleanliness level.

Hardware Requirements	<ul style="list-style-type: none"> • Available PCIe Slot: <ul style="list-style-type: none"> • Ensure the system has an available PCIe Gen6 x16 slot or two PCIe Gen5 x16 slots for optimal performance. The ConnectX-9 SuperNIC requires a full-length PCIe slot for installation. • Ensure the chassis is compatible with the form factor of the ConnectX-9 SuperNIC (typically a half-height, full-length card). • Power Supply: <ul style="list-style-type: none"> • Ensure the system's power supply unit (PSU) can provide sufficient power for the ConnectX-9 SuperNIC, typically requiring 75W from the PCIe slot. • Connectivity: <ul style="list-style-type: none"> • The ConnectX-9 SuperNIC supports Ethernet and InfiniBand network connections. Ensure the chassis is connected to the appropriate network infrastructure (switches, routers, etc.). • MCIO Harness (for dual-board setups): <ul style="list-style-type: none"> • If connecting the PCIe auxiliary extension option in the chassis, ensure the system supports the necessary MCIO harnesses for board interconnects.

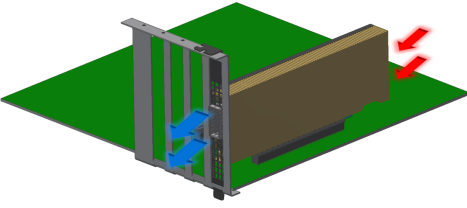
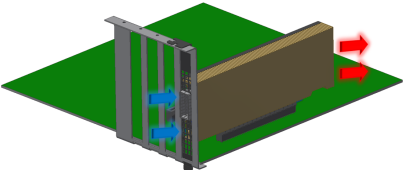
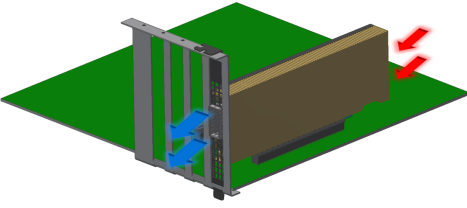
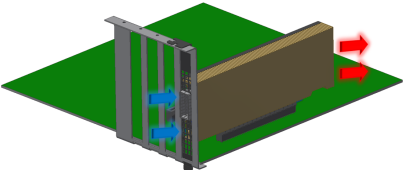
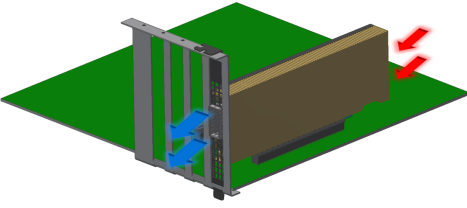
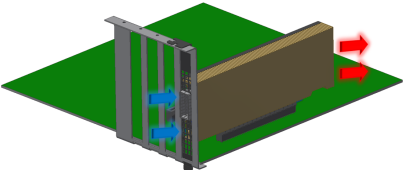
<p>Environmental Requirements</p>	<p>ConnectX-9 SuperNICs are offered with two airflow patterns: from the heatsink to the network ports, and vice versa, as shown below. Please refer to the Specifications section for airflow numbers for each specific SuperNIC model.</p> <p>The ConnectX-9 SuperNICs are available in two airflow configurations: from the heatsink to the network ports, or from the network ports to the heatsink, as illustrated below.</p> <table border="1" data-bbox="448 461 1393 804"> <thead> <tr> <th data-bbox="448 461 940 546">Airflow from the heatsink to the network ports</th> <th data-bbox="940 461 1393 546">Airflow from the network ports to the heatsink</th> </tr> </thead> <tbody> <tr> <td data-bbox="448 546 940 804">  </td> <td data-bbox="940 546 1393 804">  </td> </tr> </tbody> </table> <ul style="list-style-type: none"> • Cooling and Ventilation: <ul style="list-style-type: none"> • Adequate airflow is necessary to keep the ConnectX-9 SuperNIC cool. Ensure the chassis has sufficient cooling mechanisms, including fan trays or directed airflow near the PCIe slots. Refer to the Specifications section for the required airflow values. • The card may operate at high thermal loads during peak performance; maintaining optimal ambient temperature is crucial to prevent overheating. • Chassis Size and Slot Availability: <ul style="list-style-type: none"> • The chassis must have available PCIe slots of sufficient size (half-height/ full-length, depending on your configuration) and enough space for MCIO cable routing (if applicable). 	Airflow from the heatsink to the network ports	Airflow from the network ports to the heatsink		
Airflow from the heatsink to the network ports	Airflow from the network ports to the heatsink				
					
<p>Software Requirements</p>	<ul style="list-style-type: none"> • Operating System: <ul style="list-style-type: none"> • Ensure the operating system supports the ConnectX-9 SuperNIC, including DOCA Host for Linux and Windows Server versions. • Firmware: <ul style="list-style-type: none"> • Ensure that the firmware for the ConnectX-9 SuperNIC is up-to-date. The latest firmware versions may include critical bug fixes, performance improvements, and support for new features. • Software: <ul style="list-style-type: none"> • Ensure that the necessary network software and libraries are installed, such as: <ul style="list-style-type: none"> • DOCA-Host for Linux • Windows Server drivers for Windows environments 				

3.4 Safety Precautions Before Installing ConnectX-9 SuperNIC

The SuperNIC is being installed in a system that operates with voltages that can be lethal. Before opening the case of the system, observe the following precautions to avoid injury and prevent damage to system components.

3.4.1 Power Down and Disconnect

- **Power Off the System:** Ensure the system is powered down completely before beginning the installation process. This includes shutting down the operating system and turning off the power supply.
- **Unplug the Power Cable:** Physically disconnect the power cable from the system to prevent any electrical hazards.

3.4.2 Electrostatic Discharge (ESD) Prevention

- **Use an Anti-Static Wrist Strap:** Always wear an anti-static wrist strap to prevent electrostatic discharge (ESD) that could damage sensitive components. Attach the wrist strap to a grounded surface.
- **Work on an Anti-Static Mat:** If possible, use an anti-static mat to place the SuperNIC and other components on while working. This helps to further reduce the risk of static buildup.

3.4.3 Handle Components with Care

- **Avoid Touching the Connectors:** Handle the ConnectX-9 SuperNIC by its edges and avoid touching the connectors or PCB surface to prevent damage from oils, dirt, or static electricity.
- **Use Proper Tools:** Use appropriate tools, such as a screwdrivers, to remove any screws or fasteners. Do not force components into place.

3.4.4 Proper Grounding

- **Ensure Proper Grounding:** Make sure that the system and all components are properly grounded. This helps to minimize the risk of electrical shock or component damage.
- **Verify Grounding of Work Area:** Ensure the area where you are installing the SuperNIC is grounded and free from electrical hazards.

3.4.5 Environmental Safety

- **Work in a Well-Ventilated Area:** Ensure that the installation area is well-ventilated and free from excessive dust or humidity.
- **Ensure Clean Hands:** Before handling the ConnectX-9 SuperNIC, make sure your hands are clean and free from dirt or oils that could damage the components.

3.5 Pre-Installation Checklist

- **Unpack the ConnectX-9 SuperNIC.** Check against the package contents list that all the parts have been sent. Check the parts for visible damage that may have occurred during shipping. Please note that the cards must be placed on an antistatic surface. For package contents please refer to [Package Contents](#).

✘ Please note that if the SuperNIC is removed hastily from the antistatic bag, the plastic ziplock may harm the EMI fingers on the networking connector. Carefully remove the SuperNIC from the antistatic bag to avoid damaging the EMI fingers.

- Shut down your system if active; Turn off the power to the system, and disconnect the power cord. Refer to the system documentation for instructions. Before you install the ConnectX-9 SuperNIC, make sure that the system is disconnected from power.
- (Optional) Check the mounting bracket on the ConnectX-9 or PCIe Auxiliary Connection Card; If required for your system, replace the full-height mounting bracket that is shipped mounted on the card with the supplied low-profile bracket. Refer to [Bracket Replacement Instructions](#).

3.6 Bracket Replacement Instructions

The ConnectX-9 SuperNIC and PCIe Auxiliary Connection card are usually shipped with an assembled high-profile bracket. If this form factor is suitable for your requirements, you can skip the remainder of this section and move to [Installation Instructions](#). If you need to replace the high-profile bracket with the short bracket that is included in the shipping box, please follow the instructions in this section.

✘ During the bracket replacement procedure, do not pull, bend, or damage the EMI fingers cage. It is recommended to limit bracket replacements to three times.

To replace the bracket you will need the following parts:

- The new brackets of the proper height
- The 2 screws saved from the removal of the bracket

Removing the Existing Bracket

1. Using a torque driver, remove the two screws holding the bracket in place.
2. Separate the bracket from the ConnectX-9 SuperNIC.

✘ Be careful not to put stress on the LEDs on the SuperNIC.

3. Save the two screws.

Installing the New Bracket

1. Place the bracket onto the SuperNIC until the screw holes line up.

✘ Do not force the bracket onto the SuperNIC.

2. Screw on the bracket using the screws saved from the bracket removal procedure above.

✘ Use a torque driver to apply up to 2 lbs-in torque on the screws.

3.7 Installation Instructions

This section provides detailed instructions on how to install your SuperNIC in a system.

Choose the installation instructions according to the ConnectX-9 configuration you would like to use.

- [ConnectX-9 PCIe x16 Installation Instructions](#)
- [ConnectX-9 Extension Option \(2x PCIe x16\) Installation Instructions](#)

3.7.1 Cables and Modules

Networking Cable Installation and Uninstallation

Before connecting a cable to the SuperNIC, ensure that the bracket is fastened to the server chassis using a screw to prevent movement or unplugging of the SuperNIC when the cable is inserted or extracted.

1. All cables can be inserted or removed with the unit powered on.
2. To insert a cable, press the connector into the port receptacle until the connector is firmly seated.
 - a. Support the weight of the cable before connecting the cable to the SuperNIC. Do this by using a cable holder or tying the cable to the rack.
 - b. Determine the correct orientation of the connector to the SuperNIC before inserting the connector. Do not try and insert the connector upside down. This may damage the SuperNIC.
 - c. Insert the connector into the SuperNIC. Be careful to insert the connector straight into the cage. Do not apply any torque, up or down, to the connector cage in the SuperNIC.
 - d. Make sure that the connector locks in place.



When installing cables make sure that the latches engage.



Always install and remove cables by pushing or pulling the cable and connector in a straight line with the SuperNIC.

3. After inserting a cable into a port, the Green LED indicator will light when the physical connection is established (that is, when the unit is powered on and a cable is plugged into the port with the other end of the connector plugged into a functioning port). See [LED Interface](#) under the Interfaces section.
4. After plugging in a cable, lock the connector using the latching mechanism particular to the cable vendor. When data is being transferred the Green LED will blink. See [LED Interface](#) under the Interfaces section.
5. Care should be taken so as not to impede the air exhaust flow through the ventilation holes. Use cable lengths that allow for routing horizontally around to the side of the chassis before bending upward or downward in the rack.
6. To remove a cable, disengage the locks and slowly pull the connector away from the port receptacle. The LED indicator will turn off when the cable is unseated.

3.8 Identifying the SuperNIC in Your System

On Linux

Get the device location on the PCI bus by running `lspci` and locating lines with the string “Mellanox Technologies”:

ConnectX-9 Card Configuration	Output Example
Single-port Socket Direct Card/MultiHost (2x PCIe x16) OPN: 900-9X91E-00EB-ST0	11:00.0 Infiniband controller: Mellanox Technologies CX9 Family [ConnectX-9] 59:00.0 Infiniband controller: Mellanox Technologies CX9 Family [ConnectX-9]
Dual-port Socket Direct Card/MultiHost (2x PCIe x16) OPN: 900-9X91Q-00CN-ST0	82:00.0 Ethernet controller: Mellanox Technologies CX9 Family [ConnectX-9] 82:00.1 Ethernet controller: Mellanox Technologies CX9 Family [ConnectX-9] 84:00.0 Ethernet controller: Mellanox Technologies CX9 Family [ConnectX-9] 84:00.1 Ethernet controller: Mellanox Technologies CX9 Family [ConnectX-9] In the output example above, the first two rows indicate that one card is installed in a PCI slot with PCI Bus address 05 (hexadecimal), PCI Device number 00, and PCI Function numbers 0 and 1. The other card is installed in a PCI slot with PCI Bus address 82 (hexadecimal), PCI Device number 00, and PCI Function numbers 0 and 1. Since the two PCIe cards are installed in two PCIe slots, each card gets a unique PCI Bus and Device number. Each of the PCIe x16 busses sees two network ports; in effect, the two physical ports of the ConnectX-7 Socket Direct adapter are viewed as four net devices by the system.
Single-port with x16 PCIe Down Stream Port Extension Option OPN: 900-9X91E-00EB-DT0	84:00.0 Ethernet controller: Mellanox Technologies CX9 Family [ConnectX-9]

On Windows

1. Open Device Manager on the server. Click Start => Run, and then enter `devmgmt.msc`.
2. Expand System Devices and locate your ConnectX-9 SuperNIC.
3. Right-click the mouse on your SuperNIC's row and select Properties to display the SuperNIC properties window.
4. Click the Details tab and select Hardware IDs (Windows 2022/2019/2016/2012 R2) from the Property pull-down menu.

PCI Device (Example)

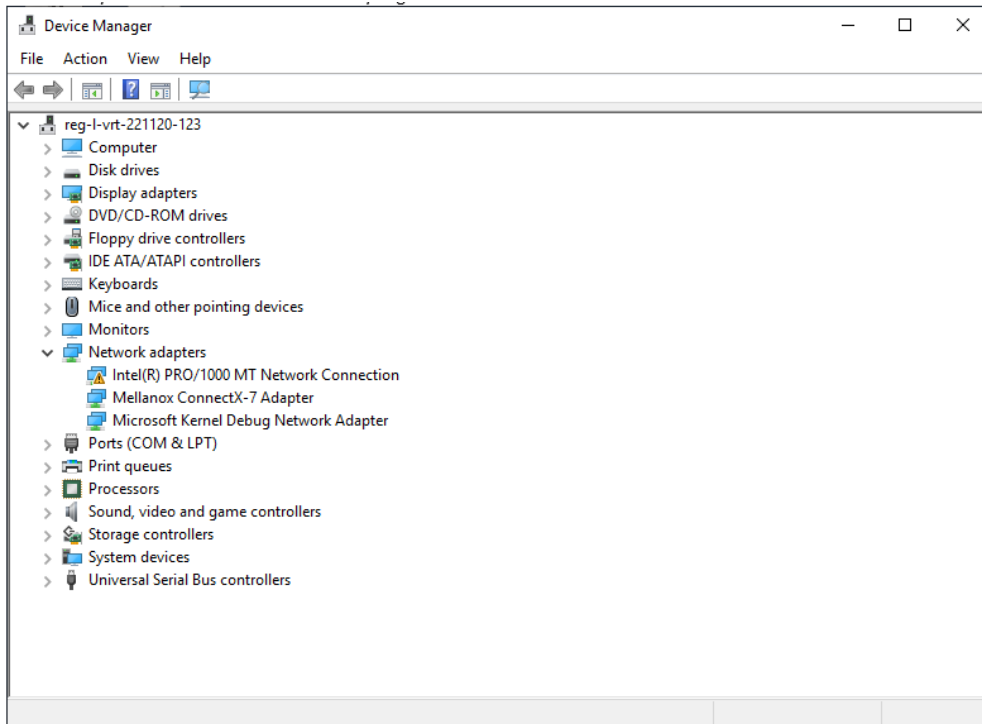

5. In the Value display box, check the fields VEN and DEV (fields are separated by '&'). In the display example above, notice the sub-string "PCI\VEN_15B3&DEV_1021": VEN is equal to 0x15B3 - this is the Vendor ID of Mellanox Technologies, and DEV is equal to 1023 (for ConnectX-9) - this is a valid NVIDIA PCI Device ID.



If the PCI device does not have a SuperNIC ID, return to Step 2 to check another device.



The list of NVIDIA PCI Device IDs can be found at the [PCI ID repository](#).

3.9 ConnectX-9 PCIe x16 Installation Instructions



- This section applies to all SuperNICs. If you plan to utilize the Socket Direct/Multi-Host configuration (2x PCIe x16), please refer to the [ConnectX-9 Extension Option \(2x PCIe x16\) Installation Instructions](#).
- Ensure that the ConnectX-9 SuperNICs are installed in PCIe slots capable of supplying the required power and airflow, as specified in the product's specifications.
- The images provided below are for illustrative purposes only.

3.9.1 Preparation

- Power down the chassis: Ensure the chassis is completely powered off. Disconnect it from any power source and remove all cables.

- Discharge static electricity: Put on an anti-static wrist strap or regularly touch a grounded metal surface to discharge any static electricity.
- **Open the chassis:**
 - Using the appropriate screwdriver, remove the screws securing the chassis side panel or top cover (depending on the chassis model). Set the screws aside in a safe place.
 - Locate an available PCIe slot that is compatible with the ConnectX-9 SuperNIC. Refer to the chassis and motherboard manual to ensure the PCIe slot supports the NIC's specifications (PCIe Gen6 x16).

3.9.2 Install the ConnectX-9 SuperNIC

- Position the SuperNIC: Carefully align the gold connector of the NIC with the PCIe slot. Ensure the card is lined up with the slot and the retention bracket aligns with the chassis screw holes.

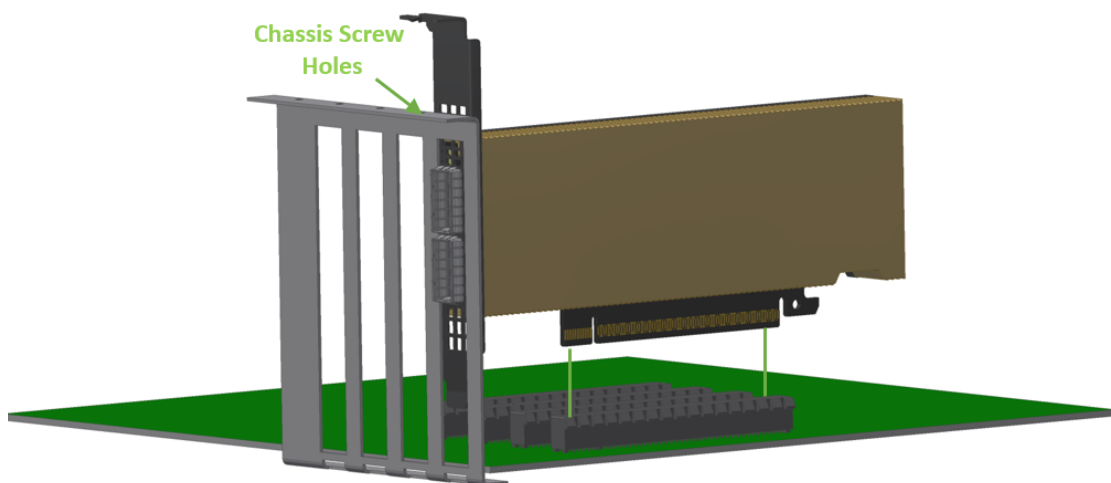

- Insert the SuperNIC: Gently but firmly push the NIC straight down into the PCIe slot until it is fully seated. Avoid excessive force.

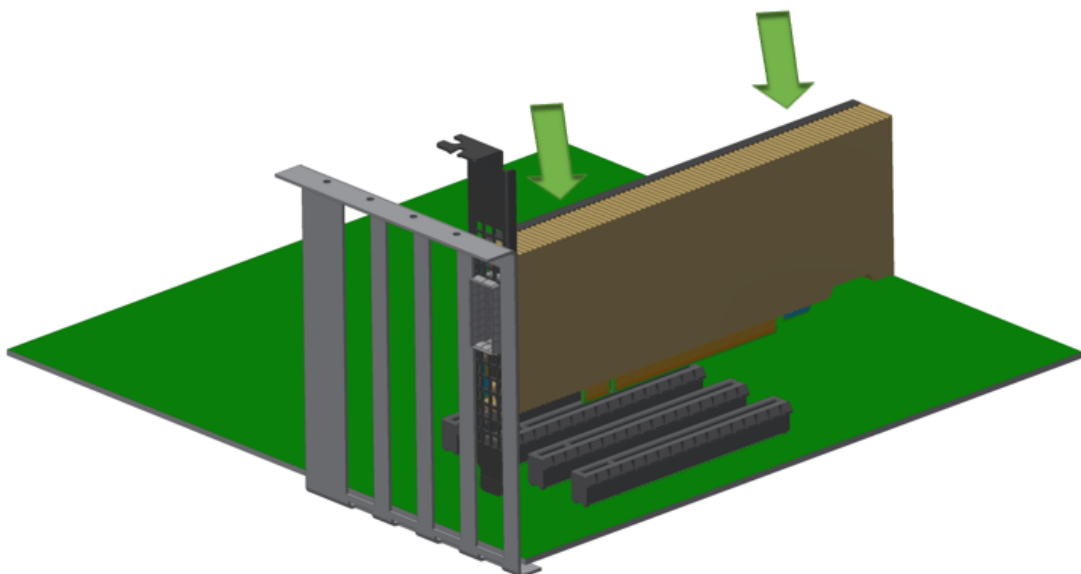

- Secure the SuperNIC: Use a screw (often provided with the chassis or card) to secure the card's metal bracket to the chassis. This prevents the card from moving and ensures a stable connection.

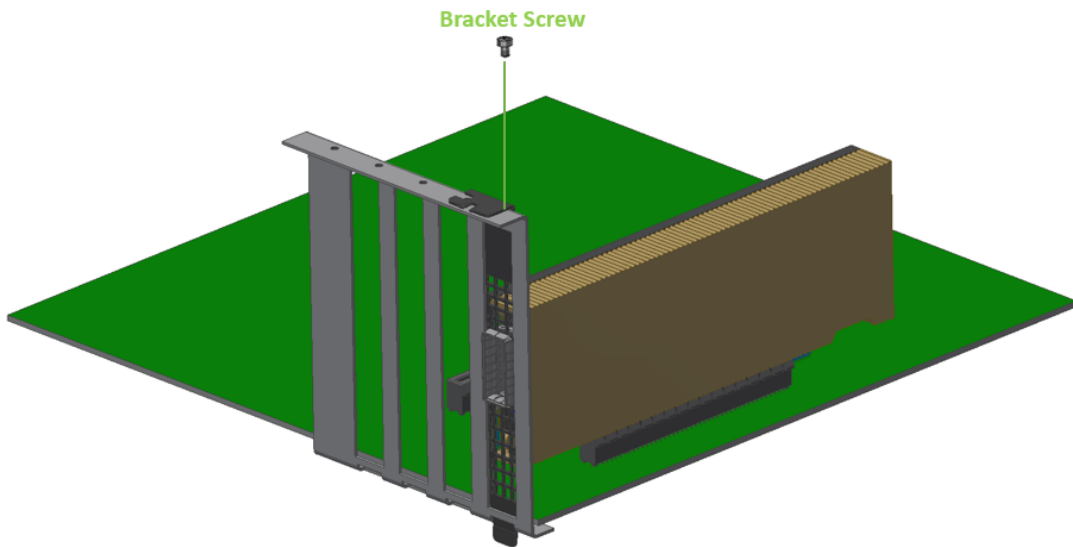

- Once the SuperNIC is securely installed, reattach the chassis side panel or top cover. Fasten the screws that were removed earlier.

3.9.3 Connect Power and Cables

- Connect the power cable to the chassis.
- Install the network cables to the newly installed SuperNIC. For more information, refer to [Networking Cable Installation](#).
- Ensure the connections are secure before powering on the chassis.

3.9.4 Power On and Verify the Installation

- Power on the chassis.
- Verify that the ConnectX-9 SuperNIC is properly recognized by the system. Depending on the operating system:
 - On Linux, run `lspci | grep Mellanox` to ensure the NIC is detected.
 - On Windows, check the Device Manager under "Network Adapters" for the presence of the new NIC.

3.9.5 Uninstallation Instructions

3.9.5.1 Preparation

- Power down the chassis:
 - Shut down the system properly, then disconnect the power supply and all cables from the chassis to ensure it's completely powered off.
 - Wait 30 seconds.
- Discharge static electricity:

- Use an anti-static wrist strap or touch a grounded metal object regularly to discharge any static electricity that could damage the components.

3.9.5.2 Open the Chassis

- Using a screwdriver, unscrew and remove the chassis side panel (or top cover, depending on the chassis design). Keep the screws in a safe place for reassembly later.
- Identify the ConnectX-9 SuperNIC you wish to remove. It will be seated in one of the PCIe slots.

3.9.5.3 Disconnect the Networking Cable

To remove the networking cable, disengage the locks and slowly pull the connector away from the port receptacle. The LED indicator will turn off when the cable is unseated. Note which cables go where if they will need to be reconnected later.

3.9.5.4 Uninstall the ConnectX-9 SuperNIC

- Locate the screw that secures the SuperNIC's metal bracket to the chassis. Use a screwdriver to remove this screw, setting it aside safely.

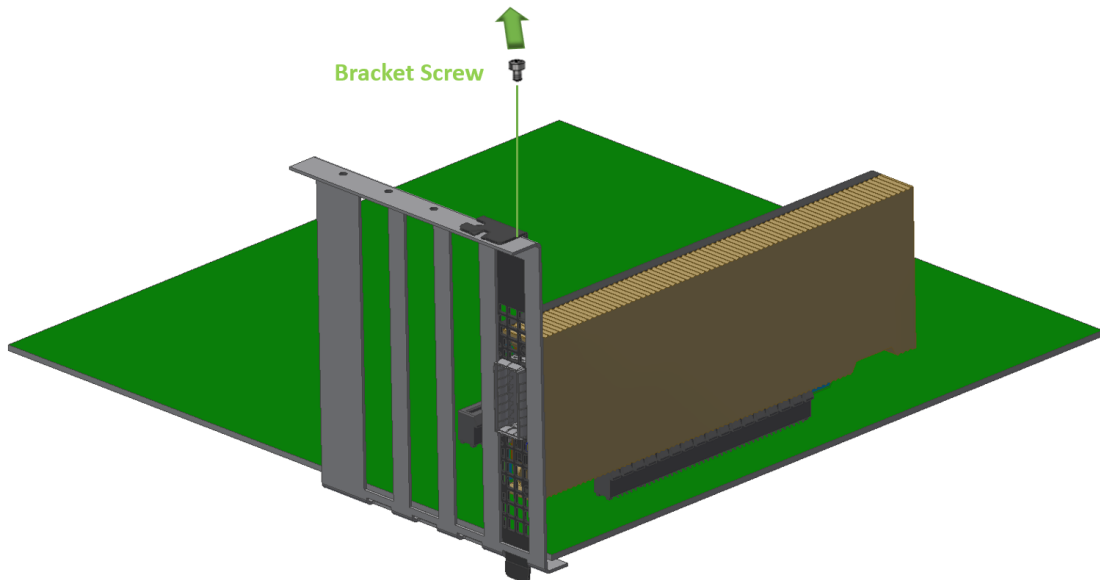

- Holding the edges of the SuperNIC, gently pull it upwards out of the PCIe slot. Apply even pressure to avoid damaging the slot or the card. Do not twist or force it out.

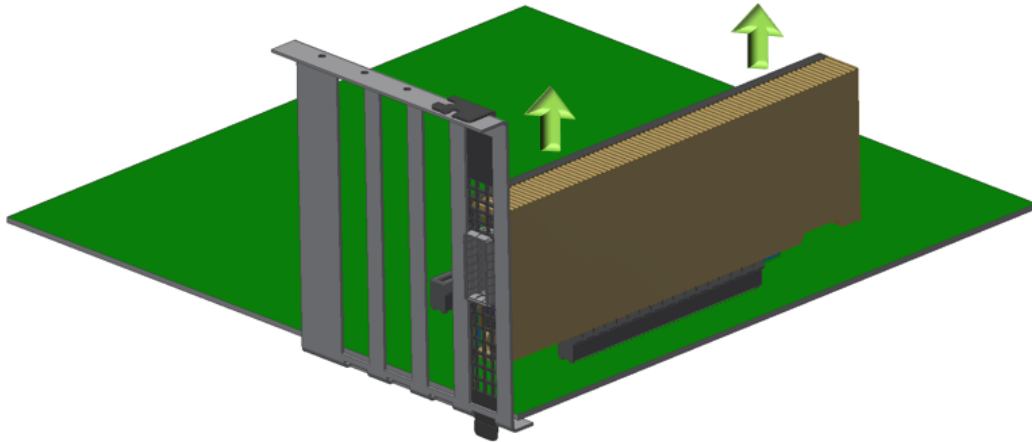

3.9.5.5 (Optional) Inspect and Clean the Components

- If needed, inspect the PCIe slot and the NIC for dust or debris. Use compressed air to clean them, but avoid touching the connectors directly.

3.9.5.6 Close the Chassis

- Once the SuperNIC is removed and any further maintenance is complete, replace the chassis side panel and secure it with the screws you removed earlier.

3.9.5.7 Reconnect Power and Cables

- Reconnect the power cable and any necessary peripherals to the system.
- Ensure all connections are secure before powering the system back on.

3.9.5.8 Power On and Verify

- Power on the system and verify that it operates correctly without the NIC.
- Depending on your operating system, you may need to check if the drivers for the NIC have been disabled or removed. On Linux, you can use `lspci` to verify the card is no longer detected, and on Windows, you can check the Device Manager under "Network Adapters."

3.10 ConnectX-9 Extension Option (2x PCIe x16) Installation Instructions



- This section applies to SuperNICs when used with the extension option.
- The images below are for illustration purposes only.

3.10.1 Installation Instructions

According to your server and your preferences, you may connect the SuperNIC to the supplied Auxiliary connection card using the harness before or after installing the SuperNIC into your chassis.

3.10.1.1 Installing the SuperNIC in the Chassis

-  Please make sure to install the ConnectX-9 cards in a PCIe slot capable of supplying the required power and airflow as stated in the [Specifications](#).

Connect the ConnectX-9 SuperNIC in an available PCI Express x16 slot in the chassis. Refer to [ConnectX-9 PCIe x16 Installation Instructions](#).

3.10.1.2 Connecting the MCIO Harness

- **Identify Connectors:** Locate the MCIO connectors on both the ConnectX-9 SuperNIC and the PCIe Auxiliary Board.
- **Connect the Harness:** Attach the MCIO harness to the connectors, ensuring a firm and secure connection. A click sound will be heard once the MCIO harness is properly installed on the cards.

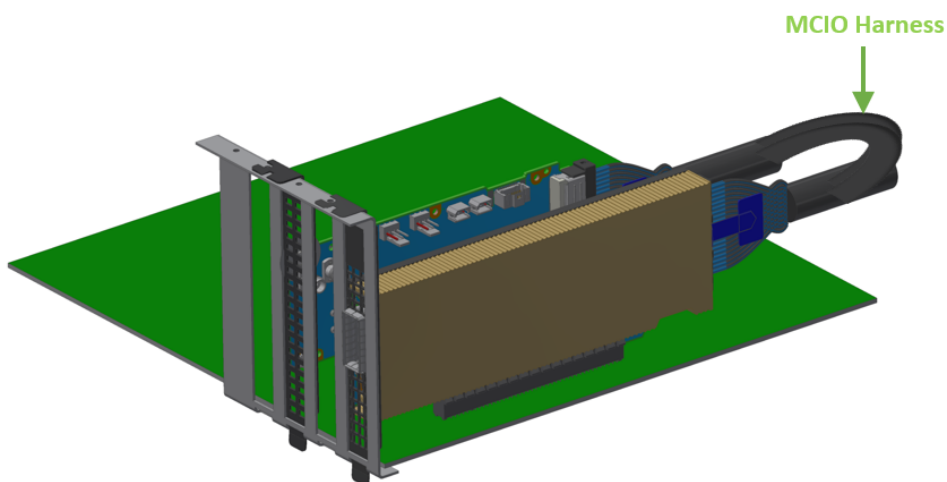

- **Route the Harness:** Carefully route the harness to avoid interference with other components and to maintain proper airflow.

3.10.1.3 Installing the PCIe Auxiliary Card in the Chassis

Plan the installation of the PCIe Auxiliary card adjacent to the SuperNIC, ensuring that the MCIO harness length (250mm) is taken into account.

- **Position the PCIe Auxiliary Board:** Align the PCIe Auxiliary Board with an available PCIe slot.

- Insert the Board: Gently insert the board into the slot, applying even pressure until it is fully seated.

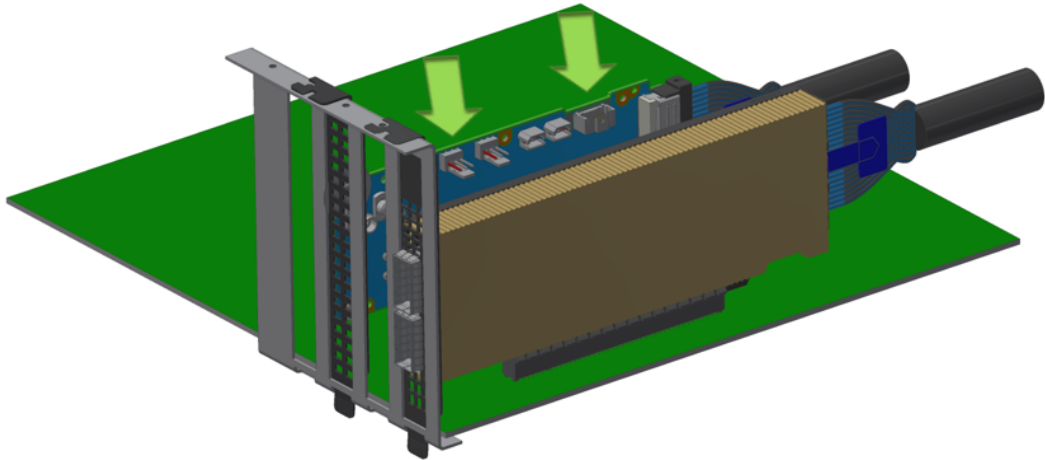

- Secure the Board: Use the chassis retention mechanisms (e.g., screws or latches) to secure the board in place.

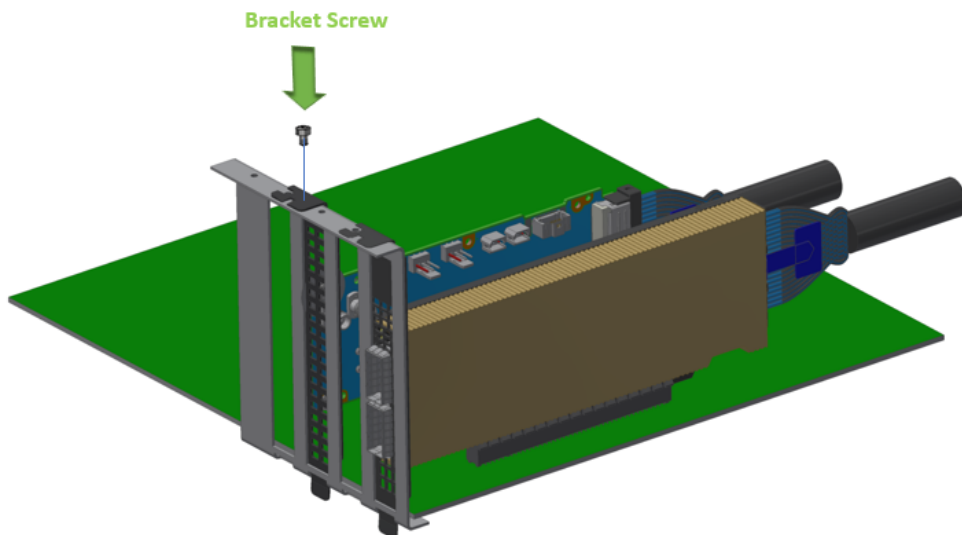

3.10.1.4 Installing the Networking Cable

For more information, refer to [Networking Cable Installation](#).

3.10.2 Uninstallation Instructions

3.10.2.1 Preparation

- Power down the chassis:
 - Shut down the system properly, then disconnect the power supply and all cables from the chassis to ensure it's completely powered off.
 - Wait 30 seconds.

- Discharge static electricity:
 - Use an anti-static wrist strap or touch a grounded metal object regularly to discharge any static electricity that could damage the components.

3.10.2.2 Open the Chassis

- Using a screwdriver, unscrew and remove the chassis side panel (or top cover, depending on the chassis design). Keep the screws in a safe place for reassembly later.
- Identify the ConnectX-9 SuperNIC you wish to remove. It will be seated in one of the PCIe slots.

3.10.2.3 Disconnect the Networking Cable

To remove the networking cable, disengage the locks and slowly pull the connector away from the port receptacle. The LED indicator will turn off when the cable is unseated. Note which cables go where if they will need to be reconnected later.

3.10.2.4 Uninstalling the PCIe Auxiliary Card

1. Locate the PCIe Auxiliary Card: Identify the PCIe Auxiliary card installed in the system, typically next to the SuperNIC.

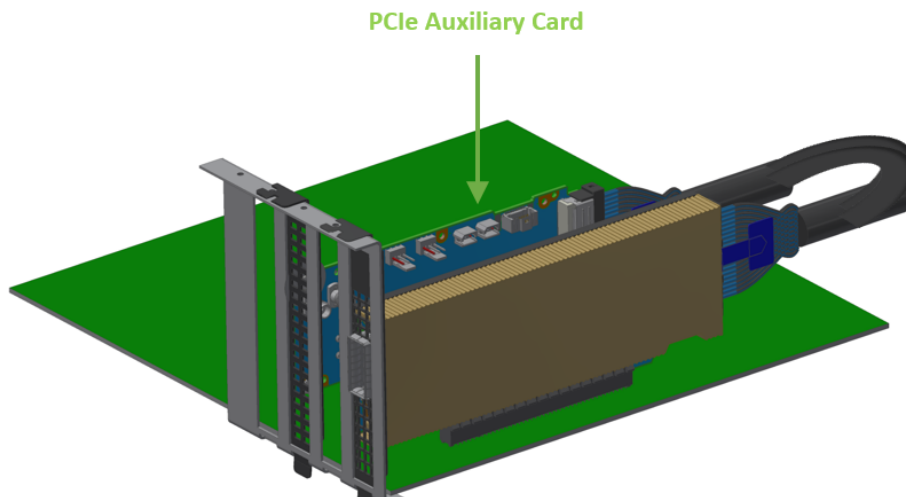

2. Disconnect the MCIO Cable:
 - a. Identify the MCIO harness that connects the PCIe Auxiliary card and the SuperNIC.
 - b. Gently disconnect the MCIO harness from the SuperNIC MCIO connector.
 - c. Similarly, disconnect the other end of the MCIO harness from the PCIe Auxiliary card.

d. Once both ends are disconnected, carefully remove the MCIO harness from the system.

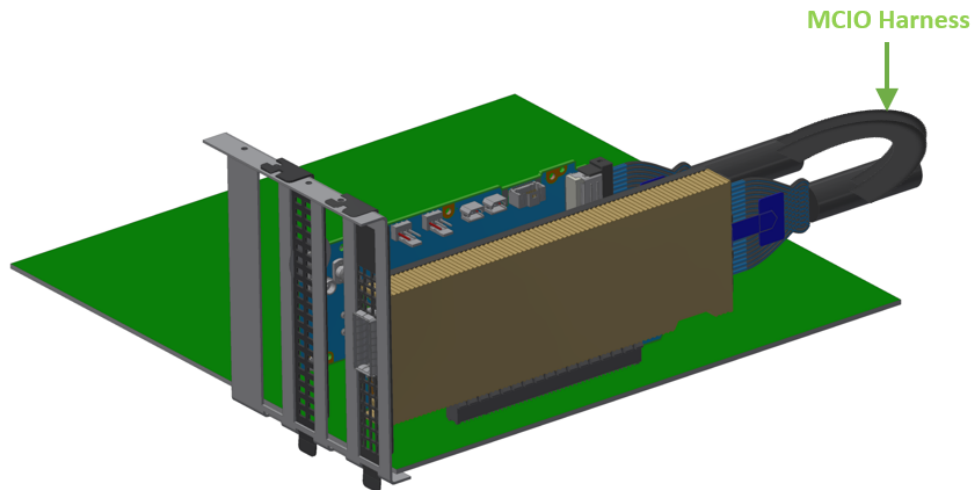

3. Release the Retention Mechanism: Disengage the hockey stick on the PCIe Auxiliary card bracket.

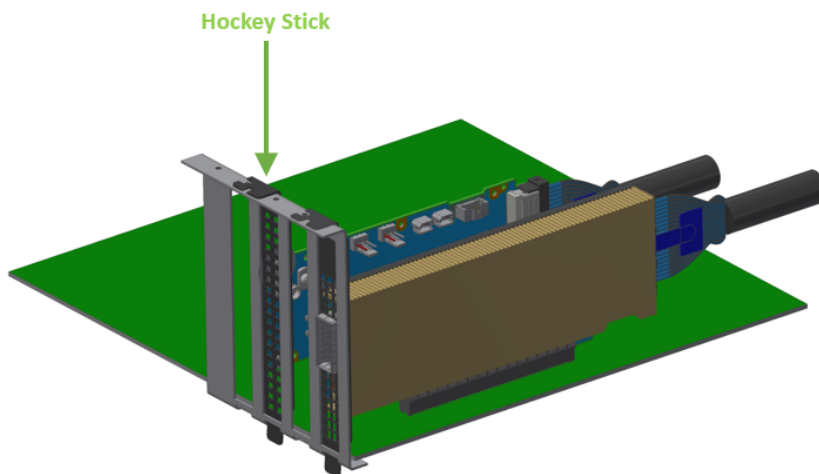

4. Remove PCIe Card: Carefully pull the PCIe Auxiliary card out of the PCIe slot, making sure to hold it by its edges. Avoid touching the connectors.

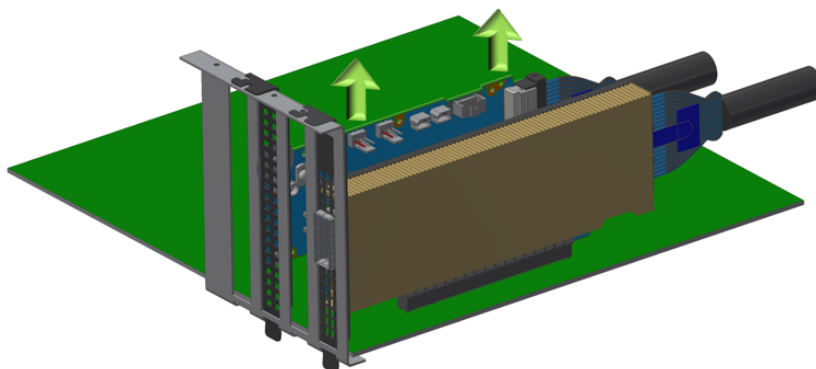

3.10.2.5 Uninstalling the ConnectX-9 SuperNIC

1. **Disconnect Cables:** If there are any additional cables or connections to the SuperNIC (such as network cables), disconnect them.
2. **Release the SuperNIC from the Slot:** If the SuperNIC is secured in place with screws or latches (Hockey Stick), remove or release them.

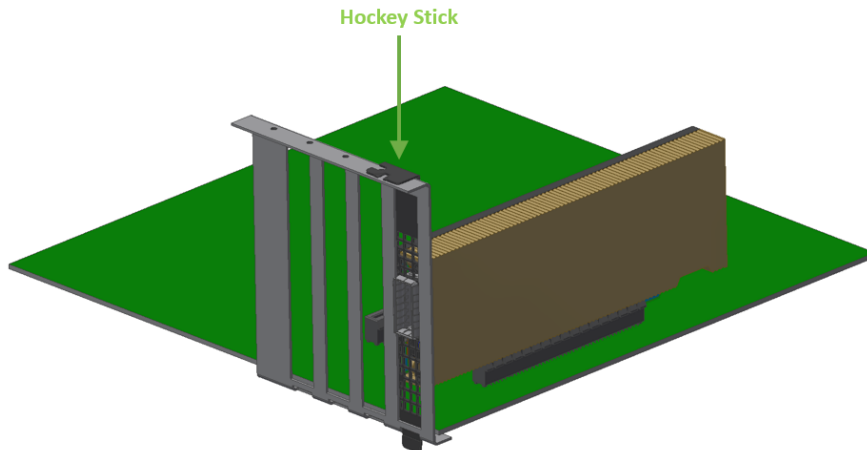

3. **Remove the SuperNIC:** Gently pull the SuperNIC from its PCIe slot, again holding it by the edges to avoid damage.

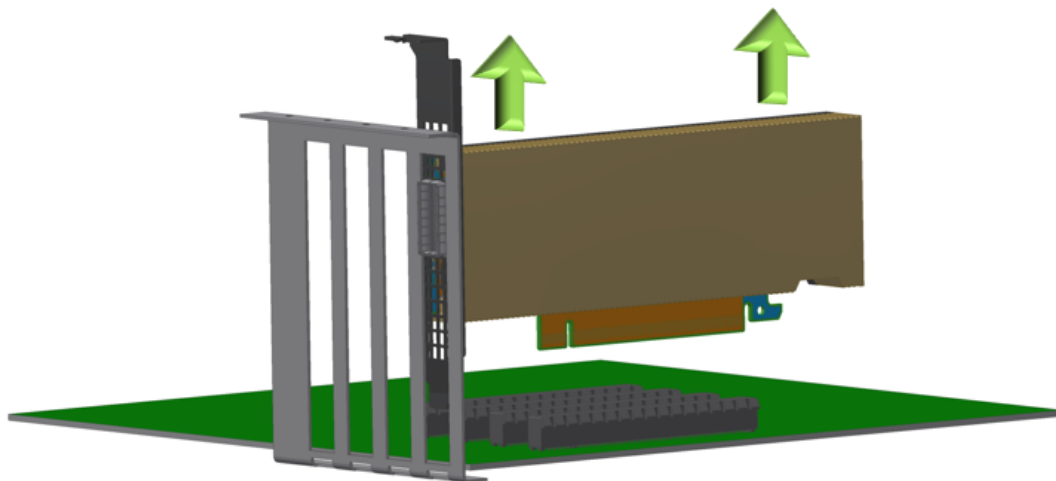

3.10.2.6 Final Steps

1. **Check for Loose Components:** Ensure that all parts, such as screws, cables, or connectors, are safely stored and not left inside the system.
2. **Inspect for Damage:** Examine the components for any signs of physical damage that might have occurred during installation or removal.

3.10.2.7 Dispose of Components Properly

If you plan on disposing any of the hardware, make sure to follow your organization's disposal guidelines for electronic waste (e-waste).

4 Driver Installation

Please refer to the relevant driver installation section.

- [DOCA-Host for Linux Driver Installation](#)
- [Windows Driver Installation](#)

4.1 DOCA-Host for Linux Driver Installation

This section describes how to install and test the DOCA-Host for Linux package on a single server with a ConnectX-9 SuperNIC installed.

4.1.1 Prerequisites

Requirements	Description
Platforms	A server platform with a ConnectX-9 SuperNIC installed.
Required Disk Space for Installation	1GB
Operating System	Linux operating system. For the list of supported operating system distributions and kernels, please refer to the DOCA-Host Release Notes .
Installer Privileges	The installation requires administrator (root) privileges on the target machine.

4.1.2 Downloading DOCA-Host

Verify that the system has a network adapter installed by running `lspci` command. The below table provides output examples per ConnectX-9 card configuration.

ConnectX-9 Card Configuration	Output Examples
Single-port Socket Direct Card/ MultiHost (2x PCIe x16)	<pre>11:00.0 Infiniband controller: Mellanox Technologies CX8 Family [ConnectX-9] 59:00.0 Infiniband controller: Mellanox Technologies CX8 Family [ConnectX-9]</pre>

ConnectX-9 Card Configuration	Output Examples
Dual-port Socket Direct Card/ MultiHost (2x PCIe x16)	<pre data-bbox="448 315 1390 421">82:00.0 Ethernet controller: Mellanox Technologies CX8 Family [ConnectX-9] 82:00.1 Ethernet controller: Mellanox Technologies CX8 Family [ConnectX-9] 84:00.0 Ethernet controller: Mellanox Technologies CX8 Family [ConnectX-9] 84:00.1 Ethernet controller: Mellanox Technologies CX8 Family [ConnectX-9]</pre> <p data-bbox="448 427 1390 660">In the output example above, the first two rows indicate that one card is installed in a PCI slot with PCI Bus address 05 (hexadecimal), PCI Device number 00, and PCI Function numbers 0 and 1. The other card is installed in a PCI slot with PCI Bus address 82 (hexadecimal), PCI Device number 00, and PCI Function numbers 0 and 1. Since the two PCIe cards are installed in two PCIe slots, each card gets a unique PCI Bus and Device number. Each of the PCIe x16 busses sees two network ports; in effect, the two physical ports of the ConnectX-7 Socket Direct adapter are viewed as four net devices by the system.</p>
Single-port with x16 PCIe Down Stream Port Extension Option	<pre data-bbox="448 705 1390 763">84:00.0 Ethernet controller: Mellanox Technologies CX8 Family [ConnectX-9]</pre>
Dual-port PCIe x16 Card	<pre data-bbox="448 884 1390 920">82:00.0 Ethernet controller: Mellanox Technologies CX8 Family [ConnectX-9] 82:00.1 Ethernet controller: Mellanox Technologies CX8 Family [ConnectX-9]</pre>
Single-port PCIe x16 Card	<pre data-bbox="448 1041 1390 1077">84:00.0 Ethernet controller: Mellanox Technologies CX8 Family [ConnectX-9]</pre>

For instructions on downloading DOCA-Host, refer to [NVIDIA DOCA Downloads](#).

4.1.3 Installing DOCA-Host

For Linux driver installation, please refer to [NVIDIA DOCA Installation Guide for Linux](#).

4.2 Windows Driver Installation

For Windows, download and install the latest WinOF-2 for Windows software package available via the NVIDIA website at: [WinOF-2 webpage](#). Follow the installation instructions included in the download package (also available from the download page).

The snapshots in the following sections are presented for illustration purposes only. The installation interface may slightly vary, depending on the operating system in use.

4.2.1 Software Requirements

For the full list of supported operating systems, please refer to the [WinOF-2 Documentation](#) -> Release Notes.

4.2.2 Downloading WinOF-2 Driver

To download the .exe file according to your Operating System, please follow the steps below:

1. Obtain the machine architecture.
 - a. To go to the Start menu, position your mouse in the bottom-right corner of the Remote Desktop of your screen.
 - b. Open a CMD console (Click Task Manager-->File --> Run new task and enter CMD).
 - c. Enter the following command.

```
echo %PROCESSOR_ARCHITECTURE%
```

 On an x64 (64-bit) machine, the output will be “AMD64”.

2. Go to the WinOF-2 web page at: <https://www.nvidia.com/en-us/networking/> > Products > Software > InfiniBand Drivers (Learn More) > Nvidia WinOF-2.
3. Download the .exe image according to the architecture of your machine (see [Step 1](#)). The name of the .exe is in the following format: MLNX_WinOF2-<version>_<arch>.exe.

 Installing the incorrect .exe file is prohibited. If you do so, an error message will be displayed.
For example, if you install a 64-bit .exe on a 32-bit machine, the wizard will display the following (or a similar) error message: “The installation package is not supported by this processor type. Contact your vendor”

4.2.3 Installing WinOF-2 Driver

The snapshots in the following sections are for illustration purposes only. The installation interface may slightly vary, depending on the used operating system.

This section provides instructions for two types of installation procedures, and both require administrator privileges:

- [Attended Installation](#)
An installation procedure that requires frequent user intervention.
- [Unattended Installation](#)
An automated installation procedure that requires no user intervention.

4.2.3.1 Attended Installation

The following is an example of an installation session.

1. Double click the .exe and follow the GUI instructions to install MLNX_WinOF2.
2. [Optional] Manually configure your setup to contain the logs option (replace “LogFile” with the relevant directory).

```
MLNX_WinOF2_<revision_version>_All_Arch.exe /v"/1*vx [LogFile]"
```

3. [Optional] If you do not want to upgrade your firmware version (i.e., MT_SKIPFWUPGRD default value is False).

```
MLNX_WinOF2_<revision_version>_All_Arch.exe /v" MT_SKIPFWUPGRD=1"
```

4. [Optional] If you do not want to install the Rshim driver, run.

```
MLNX_WinOF2_<revision_version>_All_Arch.exe /v" MT_DISABLE_RSHIM_INSTALL=1"
```

! The Rshim driver installation will fail if a prior Rshim driver is already installed. The following fail message will be displayed in the log:

"ERROR!!! Installation failed due to following errors: MlxRshim drivers installation disabled and MlxRshim drivers Installed, Please remove the following oem inf files from driver store: <oem inf list>"

5. [Optional] If you want to skip the check for unsupported devices, run.

```
MLNX_WinOF2_<revision_version>_All_Arch.exe /v" SKIPUNSUPPORTEDDEVCHECK=1"
```

6. Click Next in the Welcome screen.

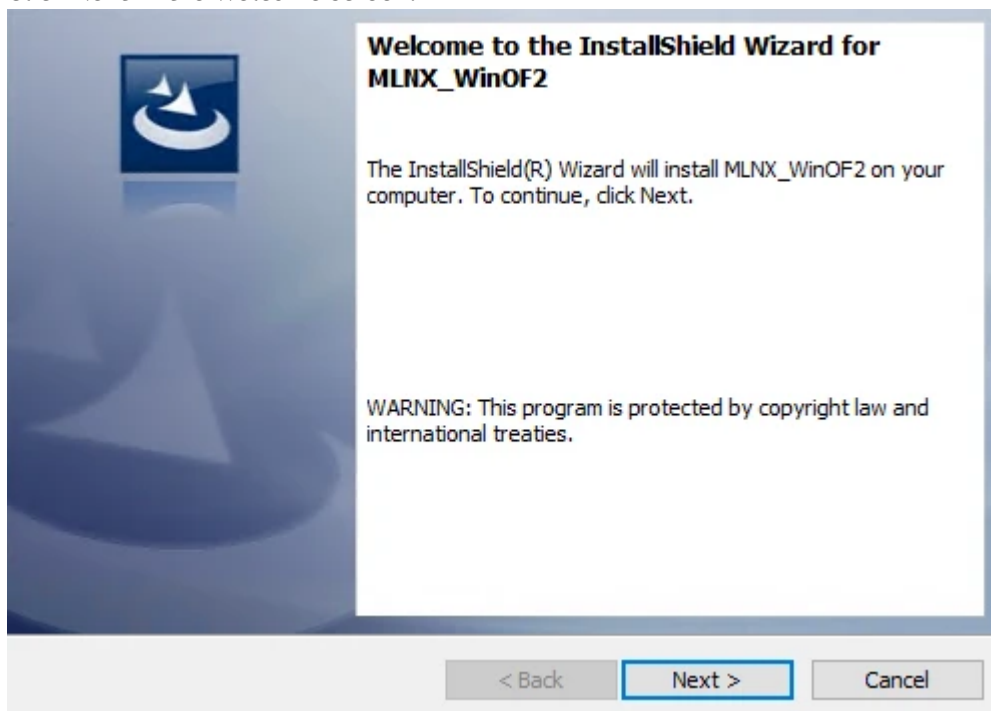

7. Read and accept the license agreement and click Next.

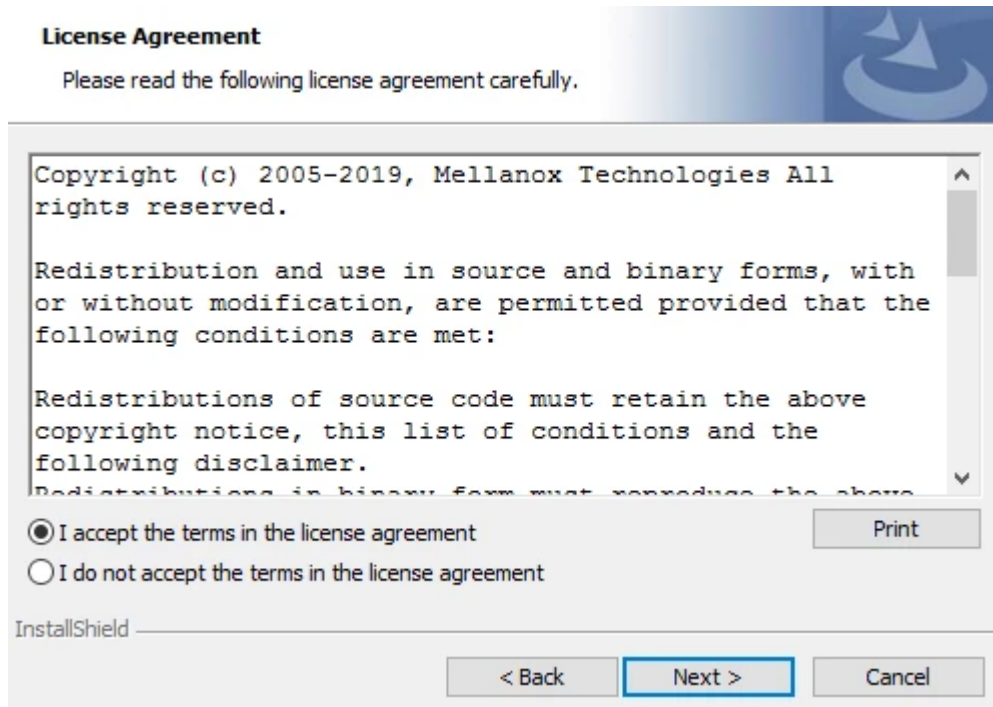

8. Select the target folder for the installation.

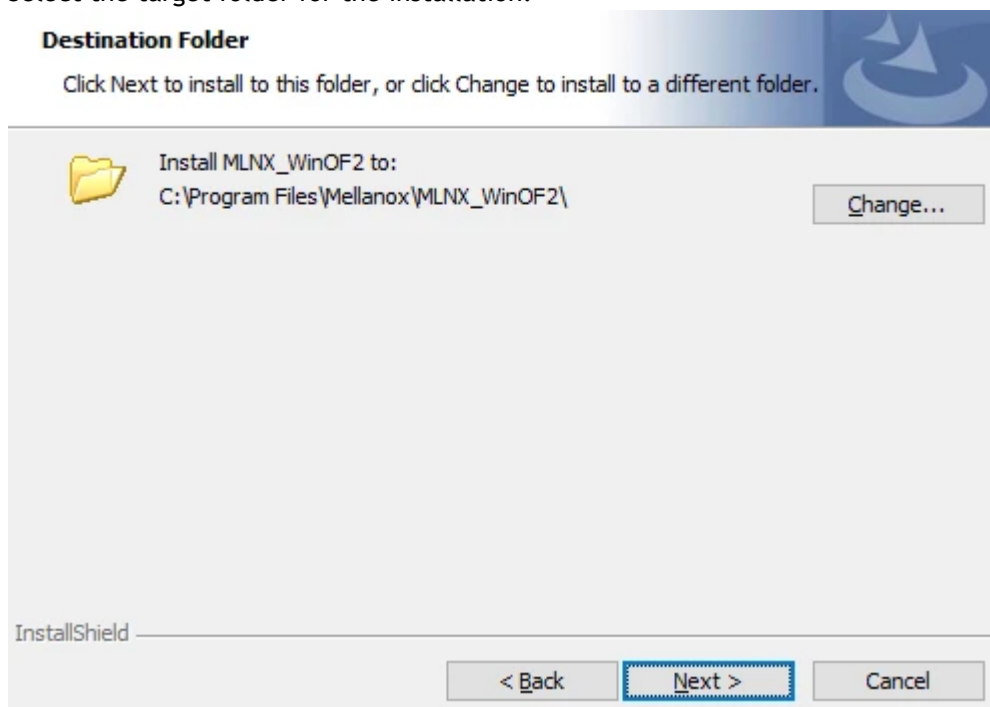

9. The firmware upgrade screen will be displayed in the following cases:

- If the user has an OEM card. In this case, the firmware will not be displayed.
- If the user has a standard NVIDIA® card with an older firmware version, the firmware will be updated accordingly. However, if the user has both an OEM card and a NVIDIA® card, only the NVIDIA® card will be updated.

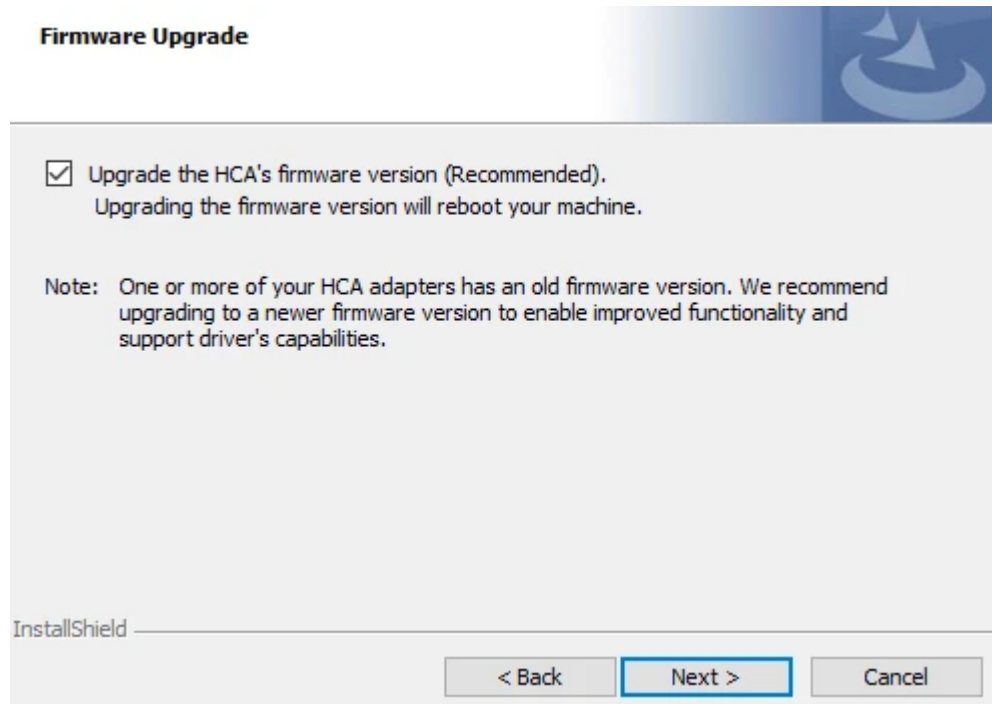

10. Select a Complete or Custom installation, follow [Step a](#) onward.

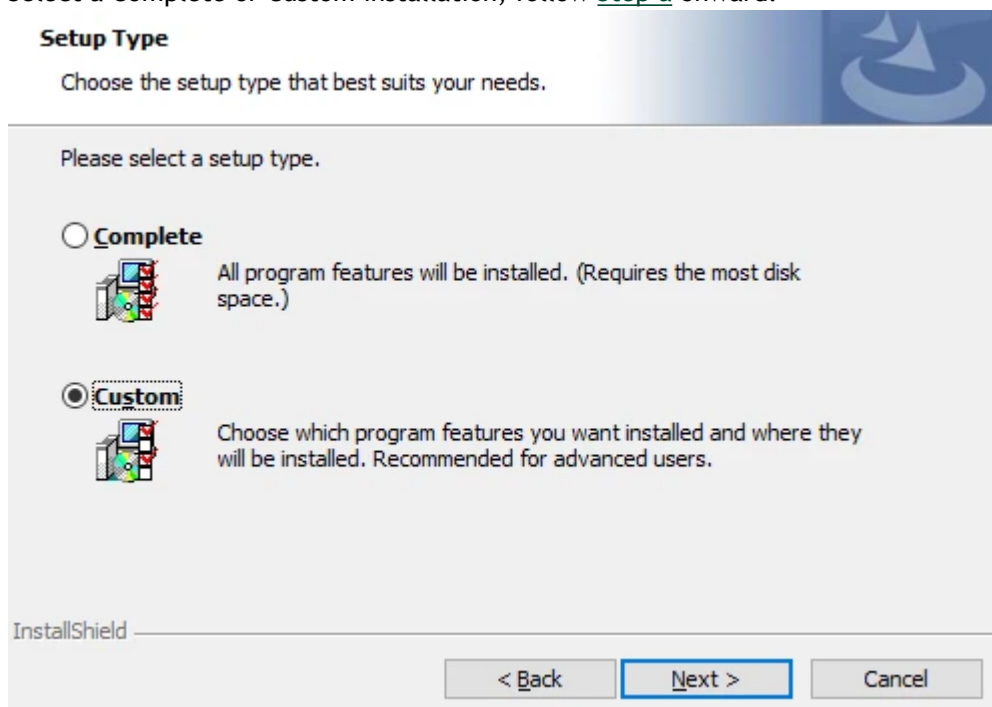

- a. Select the desired feature to install:
- Performances tools - install the performance tools that are used to measure performance in user environment
 - Documentation - contains the User Manual and Release Notes
 - Management tools - installation tools used for management, such as mlxstat

- Diagnostic Tools - installation tools used for diagnostics, such as mlx5cmd
- b. Click Next to install the desired tools.

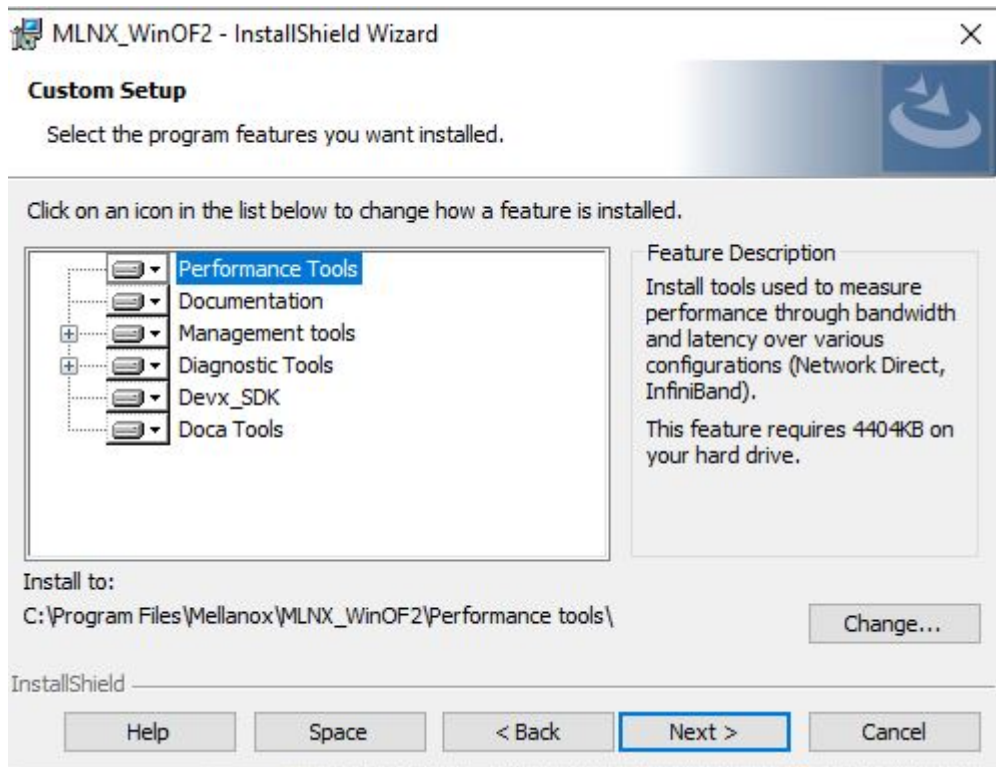

11. Click Install to start the installation.

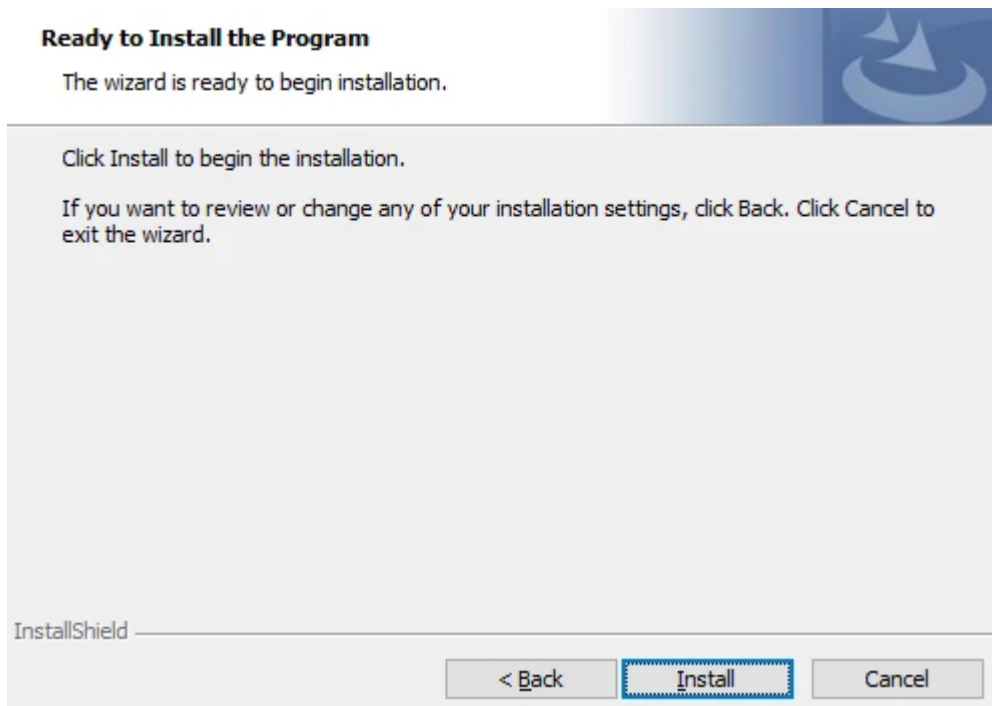

12. In case firmware upgrade option was checked in [Step 7](#), you will be notified if a firmware upgrade is required (see).

Installing MLNX_WinOF2

The program features you selected are being installed.

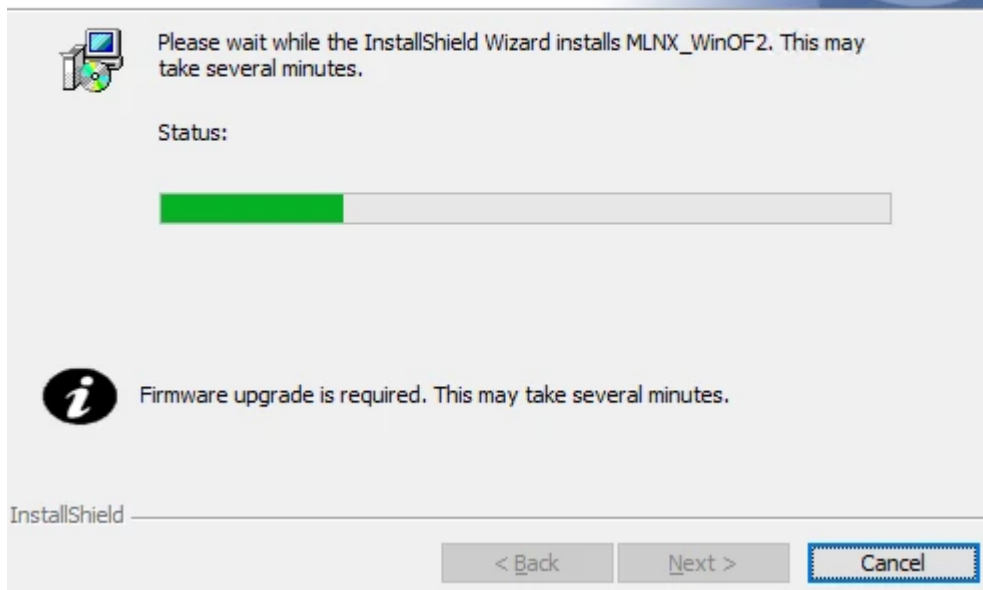

13. Click Finish to complete the installation.

Ready to Install the Program

The wizard is ready to begin installation.

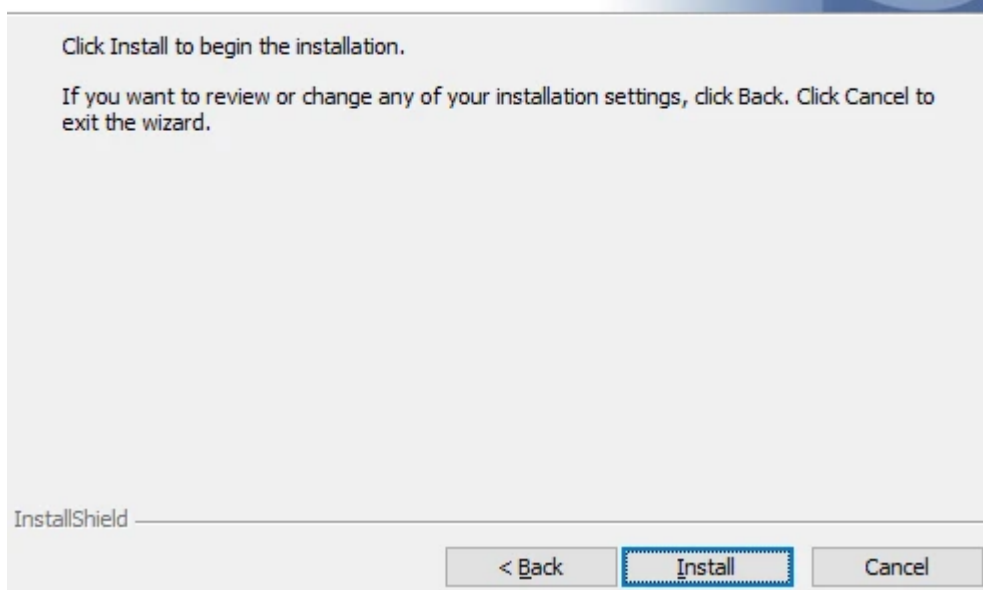

4.2.3.2 Unattended Installation



If no reboot options are specified, the installer restarts the computer whenever necessary without displaying any prompt or warning to the user. To control the reboots, use the */norestart* or */forcerestart* standard command-line options.

The following is an example of an unattended installation session.

1. Open a CMD console-> Click Start-> Task Manager File-> Run new task-> and enter CMD.
2. Install the driver. Run:

```
MLNX_WinOF2-[Driver/Version]<revision_version>_All_Arch.exe /S /v/qn
```

3. [Optional] Manually configure your setup to contain the logs option:

```
MLNX_WinOF2-[Driver/Version]<revision_version>_All_Arch.exe /S /v/qn /v"/l*v* [LogFile]"
```

4. [Optional] if you wish to control whether to install ND provider or not (i.e., *MT_NDPROPERTY* default value is *True*).

```
MLNX_WinOF2-[Driver/Version]<revision_version>_All_Arch.exe /vMT_NDPROPERTY=1
```

5. [Optional] If you do not wish to upgrade your firmware version (i.e., *MT_SKIPFWUPGRD* default value is *False*).

```
MLNX_WinOF2-[Driver/Version]<revision_version>_All_Arch.exe /vMT_SKIPFWUPGRD=1
```

6. [Optional] If you do not want to install the Rshim driver, run.

```
MLNX_WinOF2-<revision_version>_All_Arch.exe /v" MT_DISABLE_RSHIM_INSTALL=1"
```



The Rshim driver installation will fail if a prior Rshim driver is already installed. The following fail message will be displayed in the log:

```
"ERROR!!! Installation failed due to following errors: MlxRshim drivers installation disabled and MlxRshim drivers Installed, Please remove the following oem inf files from driver store: <oem inf list>"
```

7. [Optional] If you want to enable the default configuration for Rivermax, run.

```
MLNX_WinOF2-<revision_version>_All_Arch.exe /v"MT_RIVERMAX=1 /l*v* C:\Users\<user>\log.txt "
```

8. [Optional] If you want to skip the check for unsupported devices, run/

```
MLNX_WinOF2-<revision_version>_All_Arch.exe /v" SKIPUNSUPPORTEDDEVCHECK=1"
```

4.2.4 Firmware Upgrade

If the machine has a standard NVIDIA® card with an older firmware version, the firmware will be automatically updated as part of the NVIDIA® WinOF-2 package installation. For information on how to upgrade firmware manually, please refer to [MFT User Manual](#).

If the machine has a DDA (pass through) facility, firmware update is supported only in the Host. Therefore, to update the firmware, the following must be performed:

1. Return the network adapters to the Host.
2. Update the firmware according to the steps in the [MFT User Manual](#).
3. Attach the adapters back to VM with the DDA tools.

5 Firmware Upgrade

Each SuperNIC is shipped with the latest version of qualified firmware at the time of manufacturing. However, NVIDIA issues firmware updates occasionally that provide new features and bug fixes. To check that your card is programmed with the latest available firmware version, download the mlxup firmware update and query utility. The utility can query for available SuperNICs and indicate which SuperNIC require a firmware update. If the user confirms, mlxup upgrades the firmware using embedded images. The latest mlxup executable and documentation are available in [mlxup - Update and Query Utility](#).

Firmware Update Example

```
[server1]# ./mlxup
Querying Mellanox devices firmware ...
Device Type:      ConnectX-9
Part Number:      900-9X91E-00EB-ST0
Description:      NVIDIA ConnectX-9 C9180 HHHH SuperNIC, Single-cage 800Gbs XDR IB / 800GbE (default), OSFP, PCIe 6
x16 with x16 PCIe SocketDirect Extension option, Crypto Enabled, Secure Boot Enabled, Tall bracket
PCI Device Name:  0b:00.0
Base MAC:         0000e41d2d5cf810
Versions:         Current      Available
FW               28.33.0800    28.33.1000
Status:          Update required

Device Type:      ConnectX-9
Part Number:      900-9X91E-00EB-ST0
Description:      NVIDIA ConnectX-9 C9180 HHHH SuperNIC, Single-cage 800Gbs XDR IB / 800GbE (default), OSFP, PCIe 6
x16 with x16 PCIe SocketDirect Extension option, Crypto Enabled, Secure Boot Enabled, Tall bracket
Base MAC:         0000e41d2d5cf810
Versions:         Current      Available
FW               28.33.0800    28.33.1000
Status:          Up to date

Perform FW update? [y/N]: y
Device #1: Up to date
Device #2: Updating FW ... Done

Restart needed for updates to take effect.
Log File: /var/log/mlxup/mlxup-yyyyymmdd.log
```

6 SuperNIC Configurations

6.1 Setting High-Speed-Port Link Type

The following table lists the supported speeds per SuperNIC OPN, and their default networking port link type.

Model	OPN	Data Transmission Rate	Default Protocol and Rate
C9240	900-9X91Q-00CN-ST0	400GbE / 400Gb/s IB	Ethernet 400GbE
C9180	900-9X91E-00EB-ST0	800GbE / 800Gbs XDR IB	Ethernet 400GbE
	900-9X91E-00EB-DT0	800GbE / 800Gbs XDR IB	Ethernet 800GbE

You can use the [mlxconfig](#) or the [UEFI](#) tools to configure the networking high-speed ports mode.

Use the UEFI tool to configure the SuperNIC before the operating system is up. Use the mlxconfig tool to configure the SuperNIC once the operating system is up. According to your preference, use one of the below tools:

6.1.1 mlxconfig

The mlxconfig tool allows users to change device configurations without burning the firmware. The configuration is also kept after reset. By default, mlxconfig shows the configurations that will be loaded in the next boot. For more information and instructions, refer to [Using mlxconfig to Set IB/ETH Parameters](#).

6.1.2 UEFI

PreBoot drivers initialize the SuperNIC, check the port protocol type - Ethernet or InfiniBand - and bring up the port. Then, it connects to a DHCP server to obtain its assigned IP address and network parameters and the source location of the kernel/OS from which to boot. The DHCP server instructs the PreBoot drivers to access the kernel/OS through a TFTP server, an iSCSI target, or some other service. For more information and instructions, refer to [UEFI](#).

6.2 PCIe Bifurcation Configuration Options

 This section applies only to OPN 900-9X91E-00EB-DT0: NVIDIA ConnectX-9 C9180 HHHH SuperNIC, Single-cage 800Gbs XDR IB / 800GbE (default), OSFP, PCIe 6 x16 with x16 PCIe Down Stream Port Extension Option, Crypto Enabled, Secure Boot Enabled, Tall bracket

It is prohibited to change PCORE2 CONF_4.

NVIDIA ConnectX-9 SuperNIC with Down Stream provide a range of configuration scenarios to meet the demands of environments and deployments. This section describes the various connectivity options for peripherals on the PCIe, including scenarios where the ConnectX-9 SuperNIC acts as the

PCIe switch with NVMe SSDs as PCIe endpoints. While this list of scenarios is not exhaustive, it highlights the tested and verified options. Customers seeking to support unlisted configurations should contact NVIDIA Support.

The SuperNIC exposes two x16 PCIe interfaces, with internal PCIe switch architecture. The first interface is exposed via the x16 PCIe Gen6 Goldfinger connector and serves as an endpoint to the host server by default. The additional PCIe x16 interface is exposed through the MCIO connector, featuring programmable bifurcation as a downstream port. The following figure demonstrates the SuperNIC block diagram with the PCIe interfaces.

The various configuration scenarios listed in this section include a diagram and instructions on how to bifurcate the PCIe interface using the mlxconfig tool. For more information on the mlxconfig tool, please refer to [mlxconfig - Changing Device Configuration Tool](#).

Before setting the desired configuration, take note of the following warnings:

- Any customer-set configuration overrides the previous configuration values.
- Misconfiguration may harm the system.
- It is recommended to establish out-of-band connectivity to the SuperNIC before setting any of these configurations for the first time. This enables you to reset the NVConfig parameters to their default values in case of misconfiguration.

The following summarizes the available configuration scenarios.

To be updated in a future version of this document.

6.3 Port Configurations

ConnectX-9 SuperNICs offer a variety of network port configurations designed to meet the demands of different environments and deployments. This section outlines the available connectivity options for network ports per product model. While the configurations listed here are not exhaustive, they represent the tested and verified options. Customers seeking to support unlisted configurations should contact NVIDIA Support.

The Port Splitting feature allows a single physical networking module (QSFP112 or OSFP) to be split into multiple network ports. This provides flexibility in optimizing port configurations for various network topology use cases.

Key Features

- **Flexibility and Improved Traffic Segmentation:** Port splitting enables network administrators to align device ports with their network infrastructure, enabling traffic segmentation and isolation.
- **Increased Network Efficiency:** By optimizing traffic flow and reducing congestion, port splitting improves overall network efficiency. Specific physical ports can be assigned to handle certain traffic types or applications, allowing control and performance tuning.
- **Better Utilization of Resources:** Instead of needing separate SuperNICs for each logical connection or network interface, port splitting allows a single physical SuperNIC to handle multiple functions. This reduces hardware costs while maintaining high network flexibility.

Use Cases

- **Load Balancing:** Distributing traffic across multiple physical ports can improve network load distribution and balance.
- **Resiliency:** Multiple physical ports can be used for redundancy, ensuring stable network connections even if one port encounters an issue.

Each configuration in this section includes a diagram and instructions on splitting the network port using the [mlxconfig](#) or the [UEFI](#) tools. The UEFI tool configures the device before the operating system is up, while [mlxconfig](#) configures the device once the operating system is up. Select the tool based on your preference; the configuration is saved across reboots.

mlxconfig: The [mlxconfig](#) tool allows users to change configurations without burning the firmware. The configuration is also kept after reset. By default, [mlxconfig](#) shows the configurations that will be loaded in the next boot. For more information and instructions, refer to [mlxconfig](#).

UEFI: PreBoot drivers initialize the adapter device, check the port protocol type - Ethernet or InfiniBand - and bring up the port. Then it connects to a DHCP server to obtain its assigned IP address and network parameters and obtain the source location of the kernel/OS to boot from. The DHCP server instructs the PreBoot drivers to access the kernel/OS through a TFTP server, an iSCSI target, or some other service. For more information and instructions, refer to [UEFI](#).



Before setting the desired configuration, take note of the following warnings:

- The `NUM_OF_PLANES` parameter needs to be set to 0.
- Any new configuration set by the customer overwrites the previous configuration.
- Misconfiguration can potentially damage the system.
- It is recommended to establish out-of-band connectivity to the ConnectX-9 SuperNIC before setting any configuration for the first time. This allows resetting the NVConfig parameters to their default values in case of misconfiguration.
- When switching from one configuration to another (default or non-default), it is advised to first reset the device to its default configuration. This action deletes all current NVConfig settings. For the reset command and further details, refer to the [mlxconfig - Changing Device Configuration Tool](#).
- Reboot or power-cycle the SuperNIC for the new configuration to take effect.

The following table summarizes the available port-splitting configurations.

Model	OPNs	Configuration	Configuration Description
C9180	900-9X91E-00EB-STO 900-9X91E-00EB-DT0	Configuration #1 (Default)	Two Ethernet ports, each supporting 400GbE
		Configuration #2	One InfiniBand port supporting XDR 800Gb/s
		Configuration #3	Eight Ethernet ports, each supporting 100GbE
		Configuration #4	One InfiniBand port supporting XDR Lite 400Gb/s ¹
		Configuration #5	Two InfiniBand ports supporting XDR Lite 400Gb/s ¹
		Configuration #6	One InfiniBand port supporting NDR 400Gb/s
		Configuration #7	Two InfiniBand ports supporting NDR 400Gb/s
		Configuration #8	Four Ethernet ports supporting 200GbE
		Configuration #9	One Ethernet port supporting 800GbE
C9240	900-9X91Q-00CN-STO	Configuration #1 (Default)	Two Ethernet ports, each supporting 400GbE
		Configuration #2	Eight Ethernet ports, each supporting 100GbE
		Configuration #3	One InfiniBand port supporting XDR Lite 400Gb/s ¹
		Configuration #4	Two InfiniBand ports supporting XDR Lite 400Gb/s ¹
		Configuration #5	One InfiniBand port supporting NDR 400Gb/s
		Configuration #6	Two InfiniBand ports supporting NDR 400Gb/s

Note¹: For higher radix (higher host/HCA connections) with Q3400 XDR Switch.

6.3.1 C9180 Port-Splitting Configurations

The C9180 ConnectX-9 SuperNIC, featuring a single-port OSFP module, supports up to 800Gb/s. For the reconfiguration to take effect, please perform power cycle.

6.3.1.1 C9180 Configuration #1 (Default): Two Ethernet Ports, Each Supporting 400GbE

In this configuration, the device can be reconfigured to support two 400GbE Ethernet ports. The configuration is illustrated in the diagram below.

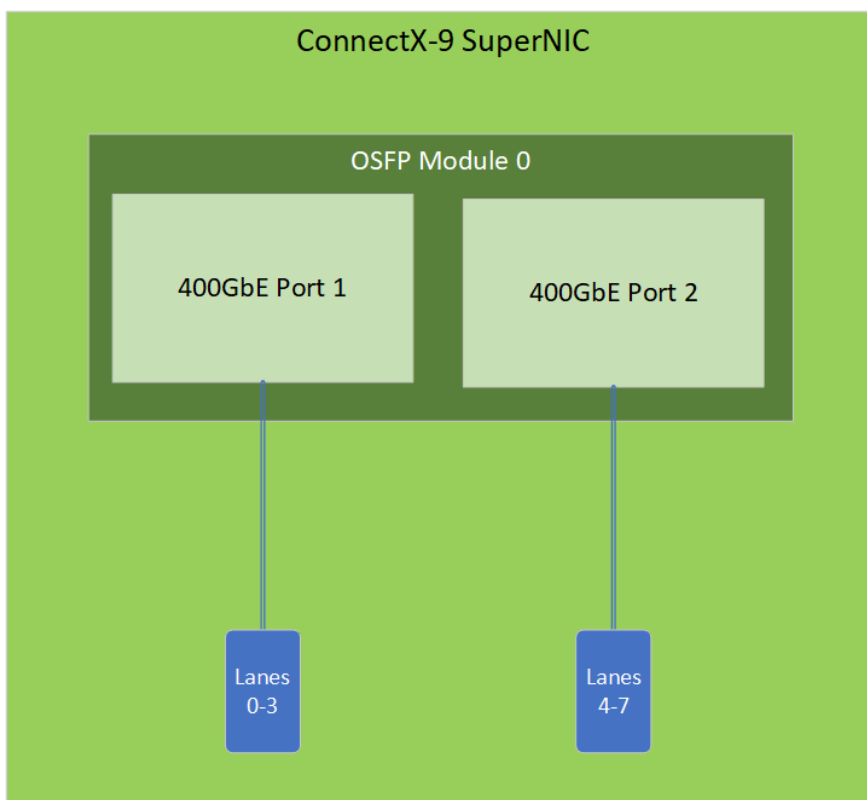

6.3.1.2 C9180 Configuration #2: One InfiniBand Port, Supporting XDR 800Gb/s

As the default configuration, the device is configured with a single InfiniBand port, providing an InfiniBand XDR rate of 800Gb/s that operates as four times 200G/s. The configuration is illustrated in the diagram below.

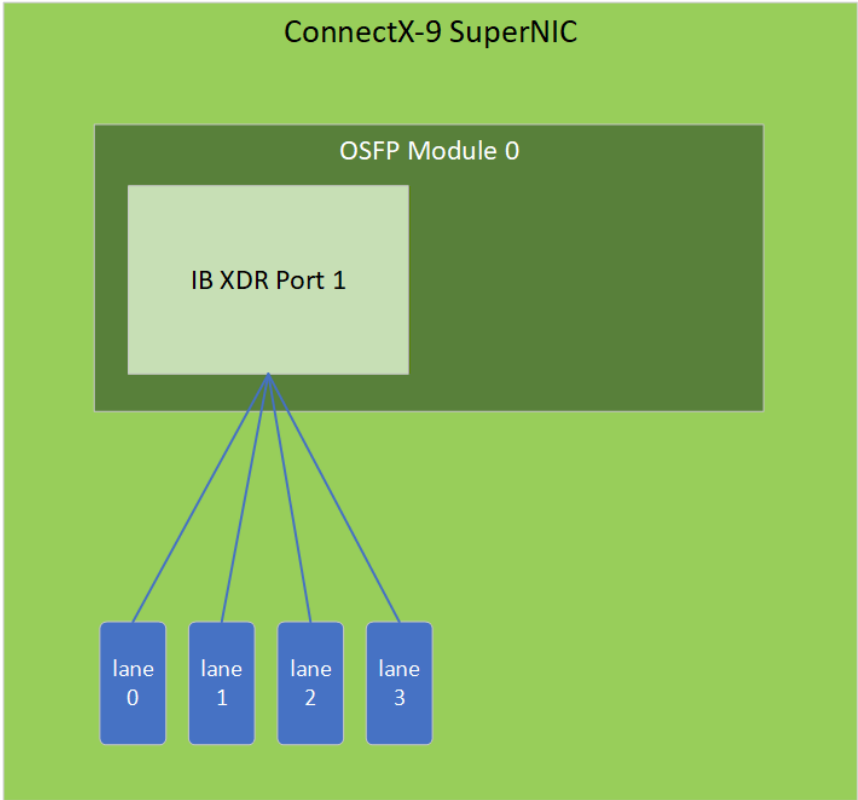

To apply this configuration, use the following mlxconfig commands:

```
mlxconfig -d <device> set LINK_TYPE_P1=1
mlxconfig -d <device> set NUM_OF_PLANES_P1=4
mlxconfig -d <device> set MODULE_SPLIT_M0[0..3]=1 MODULE_SPLIT_M0[4..15]=FF
mlxconfig -d <device> set NUM_OF_PF=1
```

6.3.1.3 C9180 Configuration #3: Eight Ethernet Ports, Each Supporting 100GbE

In this configuration, the device can be configured to support eight 100GbE Ethernet ports. The configuration is illustrated in the diagram below.

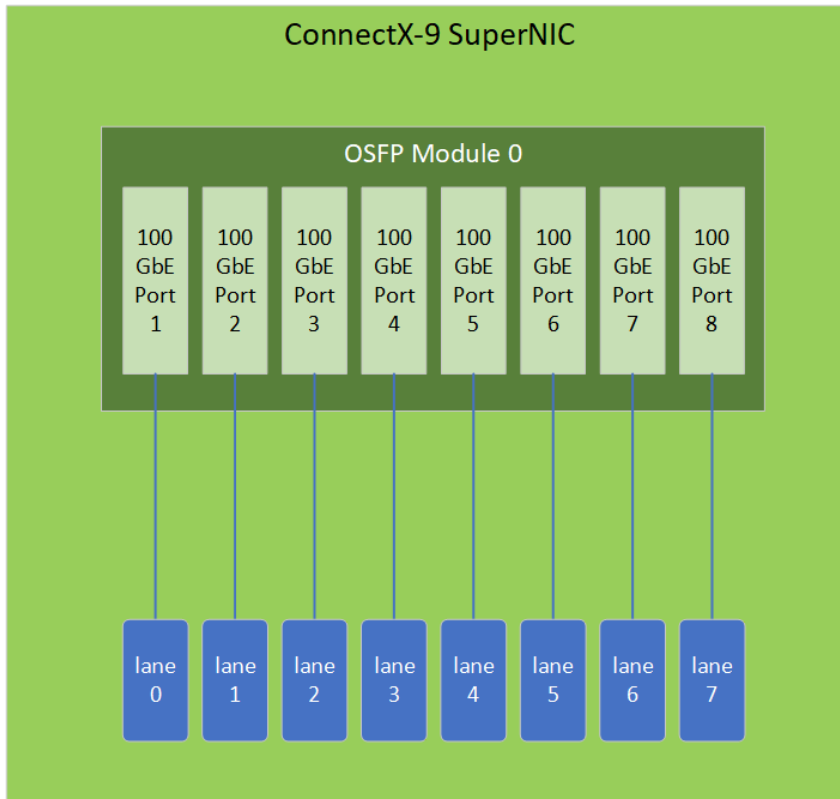

To enable this configuration, use the following mlxconfig commands:

```
mlxconfig -d <device> set MODULE_SPLIT_M0[0]=1 MODULE_SPLIT_M0[1]=2 MODULE_SPLIT_M0[2]=3 MODULE_SPLIT_M0[3]=4  
MODULE_SPLIT_M0[4]=5 MODULE_SPLIT_M0[5]=6 MODULE_SPLIT_M0[6]=7 MODULE_SPLIT_M0[7]=8 MODULE_SPLIT_M0[8..15]=FF  
mlxconfig -d <device> set NUM_OF_PF=8
```

6.3.1.4 C9180 Configuration #4: One InfiniBand Port Supporting XDR Lite 400Gb/s

In this configuration, the device can be reconfigured to support one InfiniBand port supporting XDR Lite 400Gb/s (for hosts that only support up to PCIe Gen 5.0). The configuration is illustrated in the diagram below.

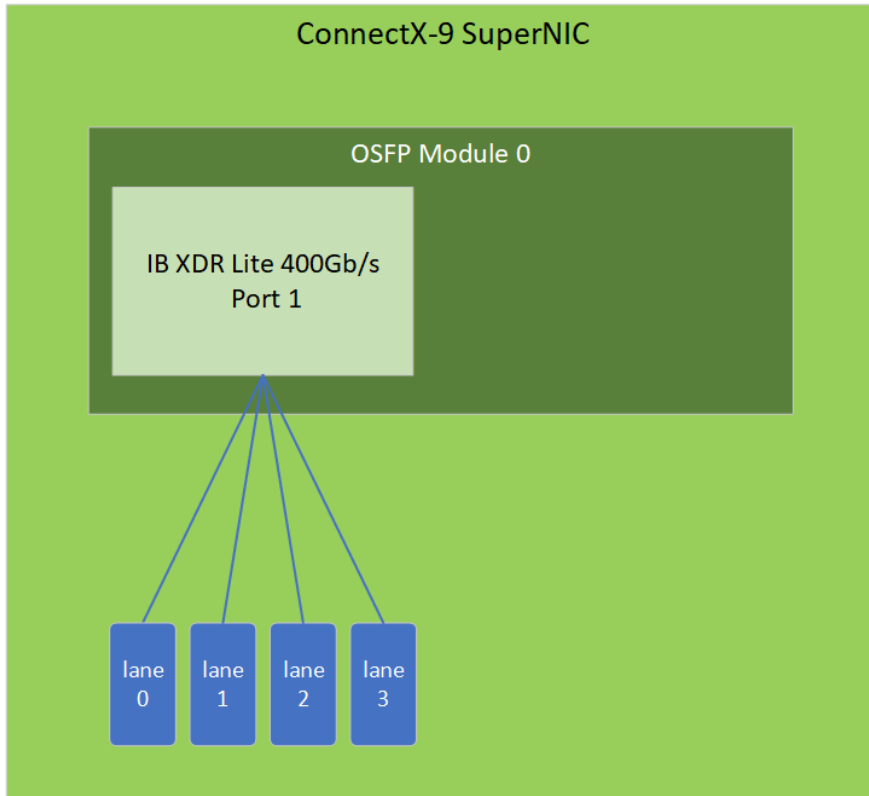

To apply this configuration, use the following mlxconfig commands:

```
mlxconfig -d <device> set MODULE_SPLIT_M0[0..3]=1 MODULE_SPLIT_M0[4..15]=FF
mlxconfig -d <device> set NUM_OF_PF=1
mlxconfig -d <device> set NUM_OF_PLANES_P1=4
mlxconfig -d <device> set LINK_TYPE_P1=1
mlxconfig -d <device> set IB_PROTO_WIDTH_EN_MASK_P1=7847937
```

6.3.1.5 C9180 Configuration #5: Two InfiniBand Ports Supporting XDR Lite 400Gb/s

In this configuration, the device can be reconfigured to support two InfiniBand ports, each supporting XDR Lite 400Gb/s (for hosts that only support up to PCIe Gen 5.0). The configuration is illustrated in the diagram below.

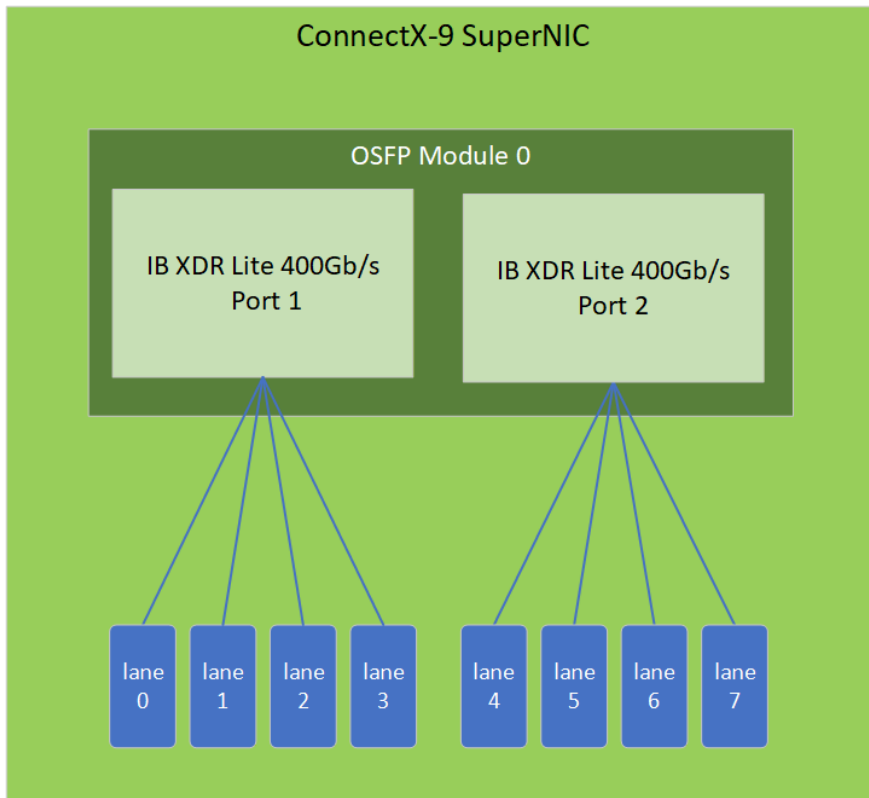

To apply this configuration, use the following mlxconfig commands:

```
mlxconfig -d <device> set MODULE_SPLIT_M0[0..3]=1 MODULE_SPLIT_M0[4..7]=2 MODULE_SPLIT_M0[8..15]=FF
mlxconfig -d <device> set NUM_OF_PF=2
mlxconfig -d <device> set NUM_OF_PLANES_P1=4 NUM_OF_PLANES_P2=4
mlxconfig -d <device> set LINK_TYPE_P1=1
mlxconfig -d <device> set IB_PROTO_WIDTH_EN_MASK_P1=7847937
--- Reboot/power cycle HCA ---
mlxconfig -d <device> set IB_PROTO_WIDTH_EN_MASK_P2=7847937
mlxconfig -d <device> set LINK_TYPE_P2=1
```

6.3.1.6 C9180 Configuration #6: One InfiniBand Port Supporting NDR 400Gb/s

In this configuration, the device can be reconfigured to one InfiniBand port supporting NDR 400Gb/s. The configuration is illustrated in the diagram below.

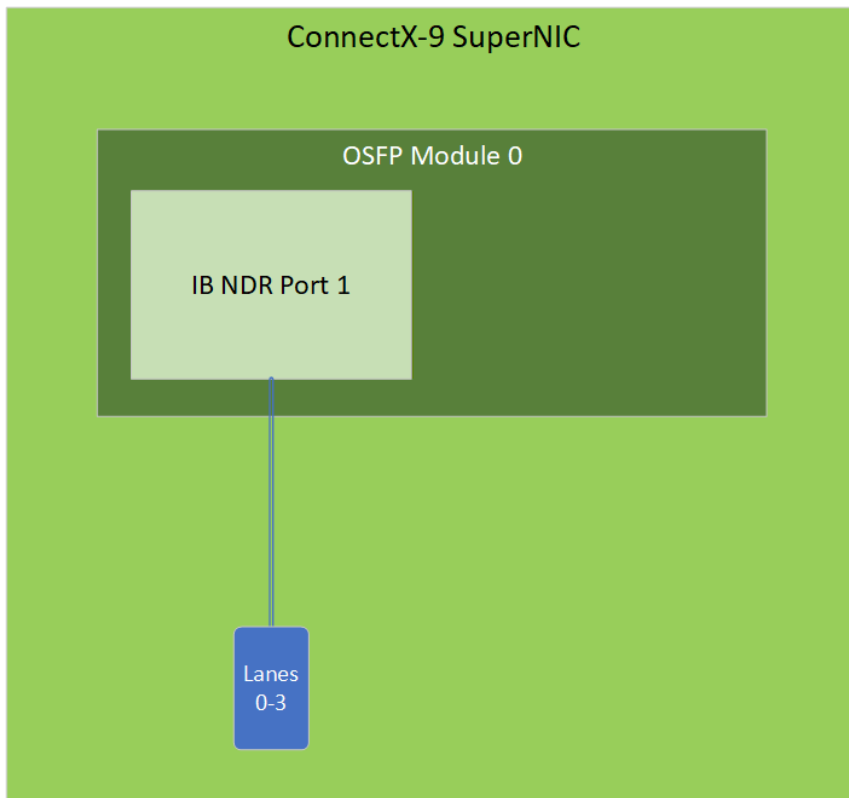

To apply this configuration, use the following mlxconfig commands:

```
mlxconfig -d <device> set MODULE_SPLIT_M0[0..3]=1 MODULE_SPLIT_M0[4..15]=FF
mlxconfig -d <device> set LINK_TYPE_P1=1
mlxconfig -d <device> set NUM_OF_PF=1
```

6.3.1.7 C9180 Configuration #7: Two InfiniBand Ports Supporting NDR 400Gb/s

In this configuration, the device can be reconfigured to two InfiniBand port supporting NDR 400Gb/s. The configuration is illustrated in the diagram below.

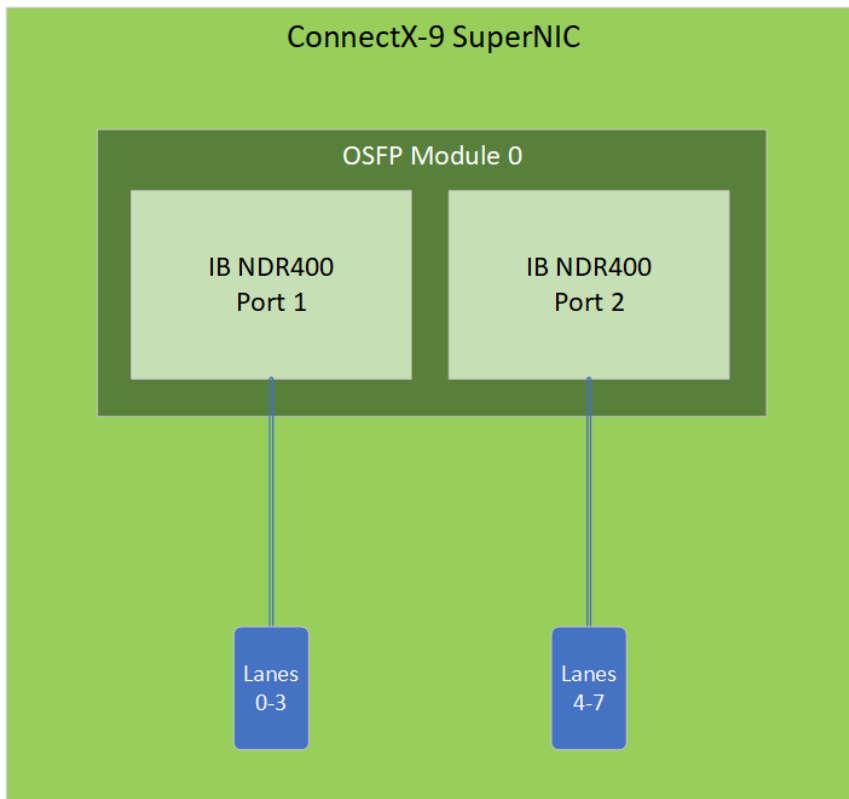

To apply this configuration, use the following mlxconfig commands:

```
mlxconfig -d <device> set MODULE_SPLIT_M0[0..3]=1 MODULE_SPLIT_M0[4..7]=2 MODULE_SPLIT_M0[8..15]=FF
mlxconfig -d <device> set LINK_TYPE_P1=1
mlxconfig -d <device> set NUM_OF_PP=2
---- Reboot/power cycle HCA ----
mlxconfig -d <device> set LINK_TYPE_P2=1
```

6.3.1.8 C9180 Configuration #8: Four Ethernet Ports Supporting 200GbE

In this configuration, the device can be reconfigured to four Ethernet ports, each supporting 200GbE. The configuration is illustrated in the diagram below.

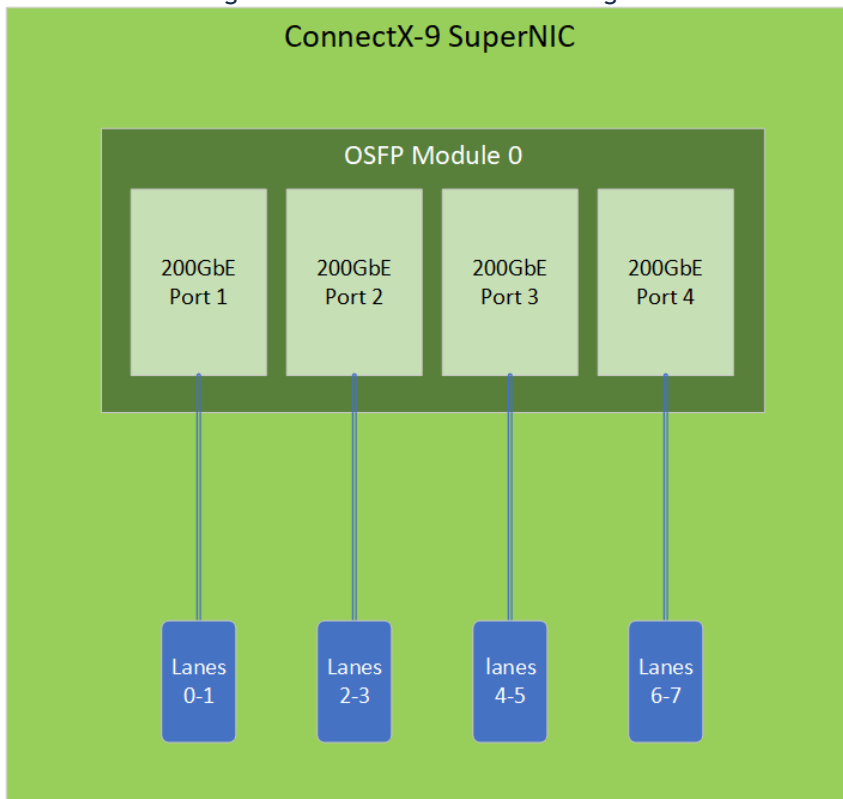

To apply this configuration, use the following mlxconfig commands:

```
mlxconfig -d <device> set MODULE_SPLIT_M0[0..1]=1 MODULE_SPLIT_M0[2..3]=2 MODULE_SPLIT_M0[4..5]=3
MODULE_SPLIT_M0[6..7]=4 MODULE_SPLIT_M0[8..15]=FF
mlxconfig -d <device> set NUM_OF_PP=4
---- Reboot/power cycle HCA ----
mlxconfig -d <device> set LINK_TYPE_P2=2 LINK_TYPE_P3=2 LINK_TYPE_P4=2
```

6.3.1.9 C9180 Configuration #9: One Ethernet Port Supporting 800GbE

In this configuration, the device can be reconfigured to one Ethernet port supporting 800GbE. The configuration is illustrated in the diagram below.

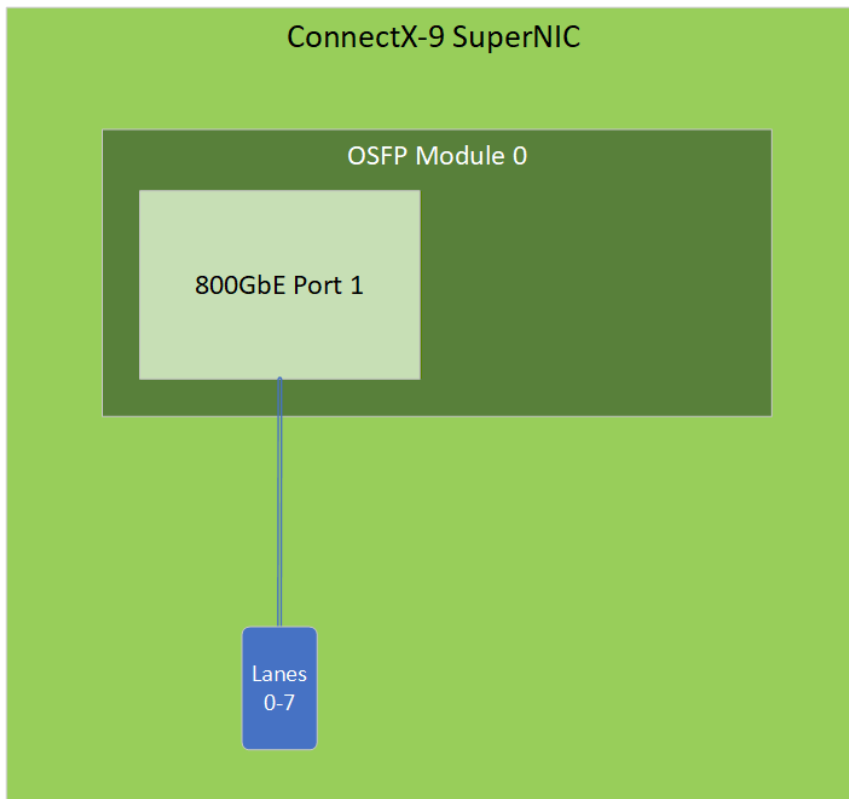

To apply this configuration, use the following mlxconfig commands:

```
mlxconfig -d <device> set MODULE_SPLIT_M0[0..7]=1 MODULE_SPLIT_M0[8..15]=PF
mlxconfig -d <device> set NUM_OF_PP=1
```

6.3.2 C9240 Port-Splitting Configurations

The C9240 ConnectX-9 SuperNIC, featuring dual QSFP modules, supports up to 400Gb/s per port. For the reconfiguration to take effect, please perform power cycle.

6.3.2.1 C9240 Configuration #1 (Default): Two Ethernet Ports, Each Supporting 400GbE

By default, the device is configured with two Ethernet ports, each supporting 400Gb/s. The configuration is illustrated in the diagram below.

ConnectX-9 SuperNIC

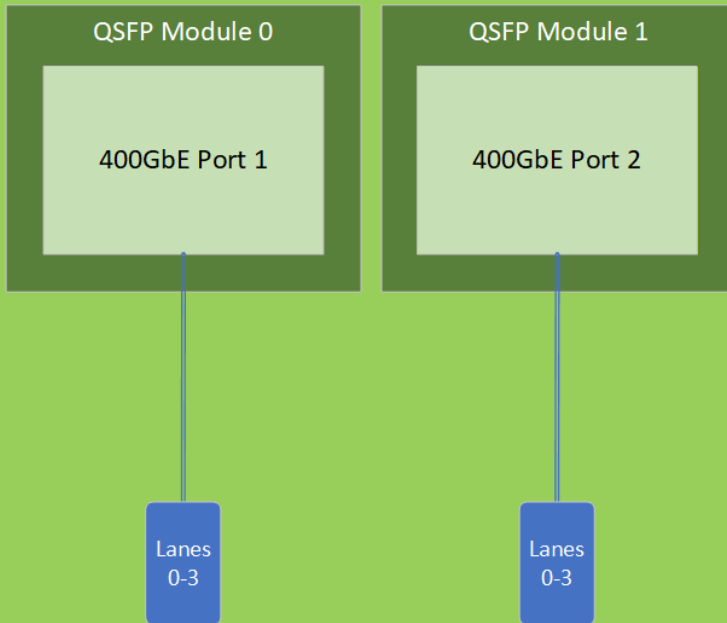

6.3.2.2 C9240 Configuration #2: Eight Ethernet Ports, Each Supporting 100GbE

In this configuration, the device can be configured to support eight 100GbE Ethernet ports, each supporting 100GbE, with four ports per module. The configuration is illustrated in the diagram below.

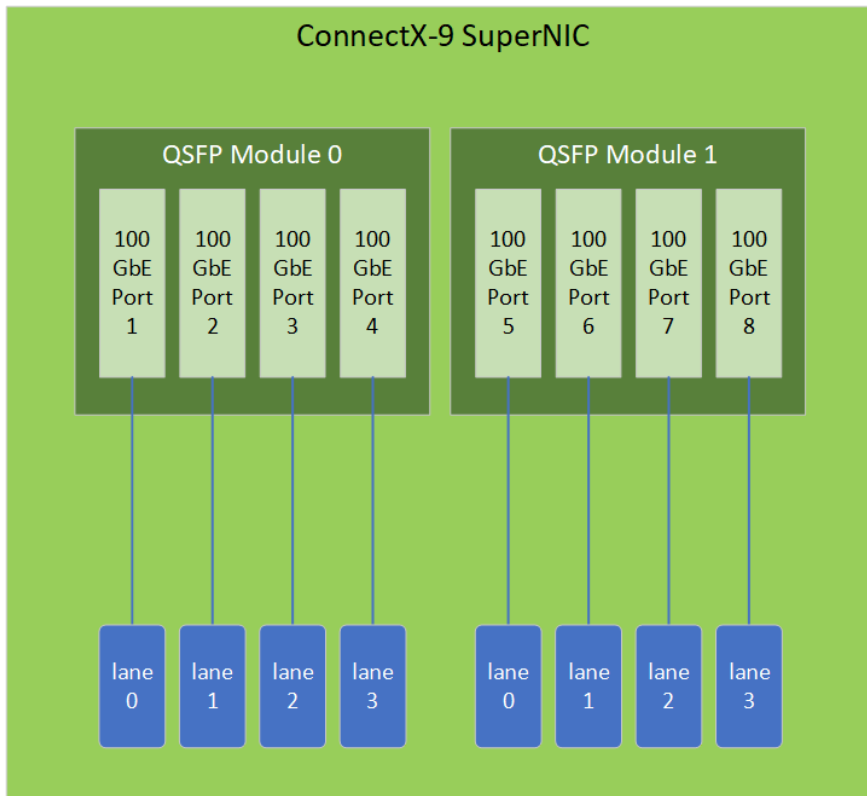

To apply this configuration, use the following mlxconfig commands:

```
mlxconfig -d <device> set MODULE_SPLIT_M0[0]=1 MODULE_SPLIT_M0[1]=2 MODULE_SPLIT_M0[2]=3 MODULE_SPLIT_M0[3]=4  
MODULE_SPLIT_M0[4..15]=FF  
mlxconfig -d <device> set MODULE_SPLIT_M1[0]=1 MODULE_SPLIT_M1[1]=2 MODULE_SPLIT_M1[2]=3 MODULE_SPLIT_M1[3]=4  
MODULE_SPLIT_M1[4..15]=FF
```

6.3.2.3 C9240 Configuration #3: One InfiniBand Port Supporting XDR Lite 400Gb/s¹

In this configuration, the device can be reconfigured to support one InfiniBand port supporting XDR Lite 400Gb/s (for hosts that only support up to PCIe Gen 5.0). The configuration is illustrated in the diagram below.

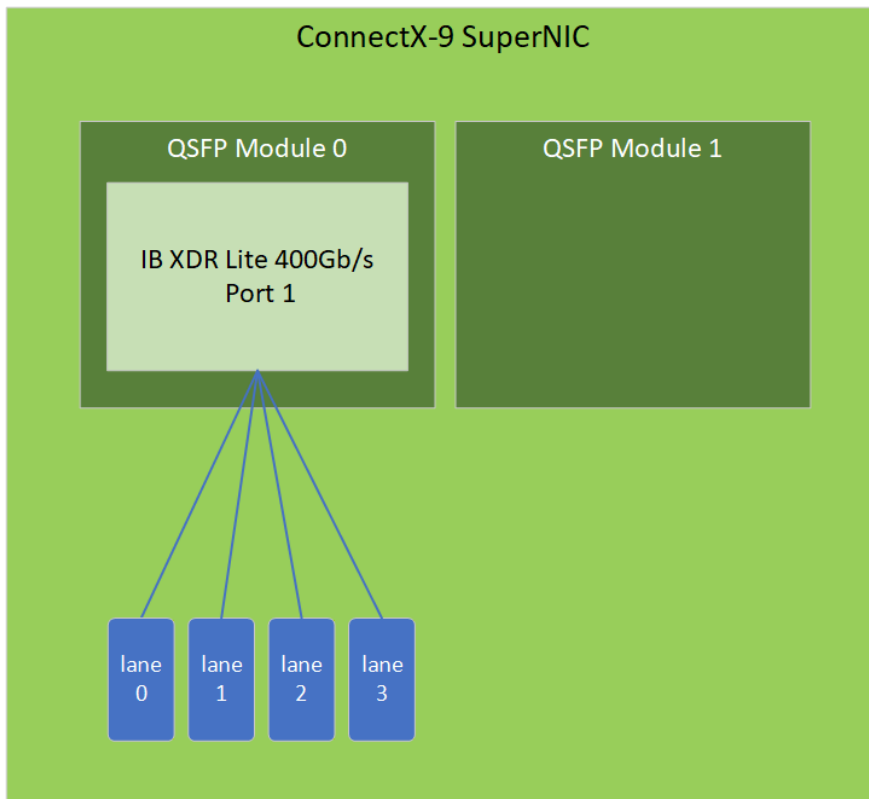

```

mlxconfig -d <device> set MODULE_SPLIT_M1[0..15]=FF
mlxconfig -d <device> set LOAD_BALANCE_MODE_P1=2
mlxconfig -d <device> set LINK_TYPE_P1=1
mlxconfig -d <device> set IB_PROTO_WIDTH_EN_MASK_P1=7847937
mlxconfig -d <device> set NUM_OF_PLANES_P1=4

```

6.3.2.4 C9240 Configuration #4: Two InfiniBand Ports Supporting XDR Lite 400Gb/s

In this configuration, the device can be reconfigured to support two InfiniBand ports, each supporting XDR Lite 400Gb/s (for hosts that only support up to PCIe Gen 5.0). The configuration is illustrated in the diagram below.

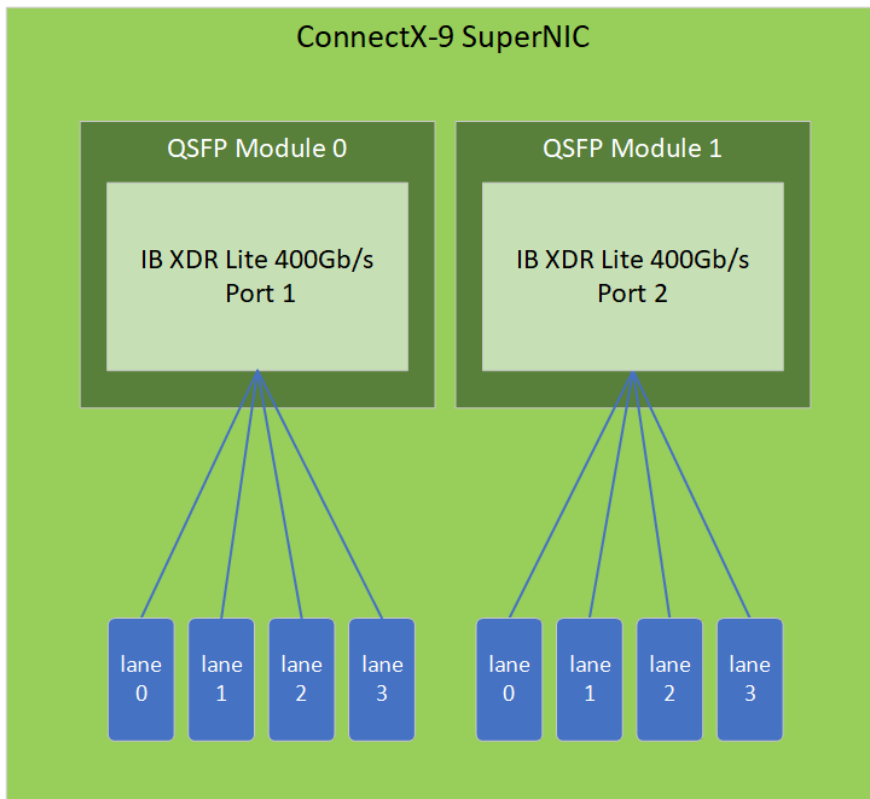

To apply this configuration, use the following mlxconfig commands:

```
mlxconfig -d <device> set LOAD_BALANCE_MODE_P1=2 LOAD_BALANCE_MODE_P2=2
mlxconfig -d <device> set LINK_TYPE_P1=1 LINK_TYPE_P2=1
mlxconfig -d <device> set IB_PROTO_WIDTH_EN_MASK_P1=7847937 IB_PROTO_WIDTH_EN_MASK_P2=7847937
mlxconfig -d <device> set NUM_OF_PLANES_P1=4 NUM_OF_PLANES_P2=4
```

6.3.2.5 C9240 Configuration #5: One InfiniBand Port Supporting NDR 400Gb/s

In this configuration, the device can be reconfigured to one InfiniBand port supporting NDR 400Gb/s. The configuration is illustrated in the diagram below.

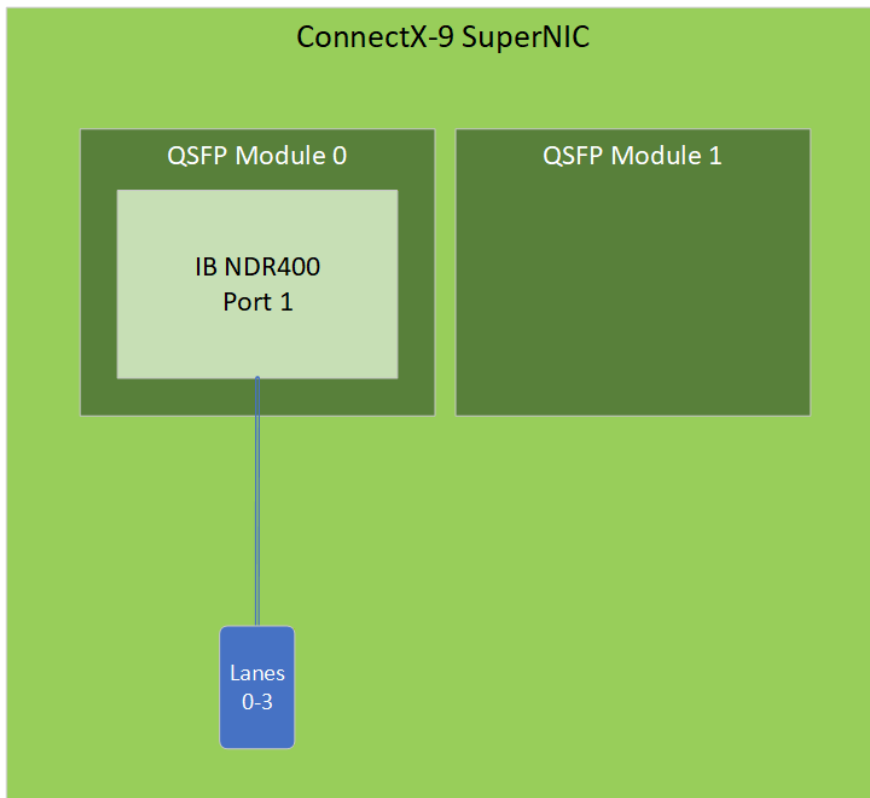

To apply this configuration, use the following mlxconfig commands:

```
mlxconfig -d <device> set MODULE_SPLIT_M1[0..15]=FF  
mlxconfig -d <device> set LINK_TYPE_P1=1
```

6.3.2.6 C9240 Configuration #6: Two InfiniBand Ports Supporting NDR 400Gb/s

In this configuration, the device can be reconfigured to two InfiniBand ports, each supporting NDR 400Gb/s. The configuration is illustrated in the diagram below.

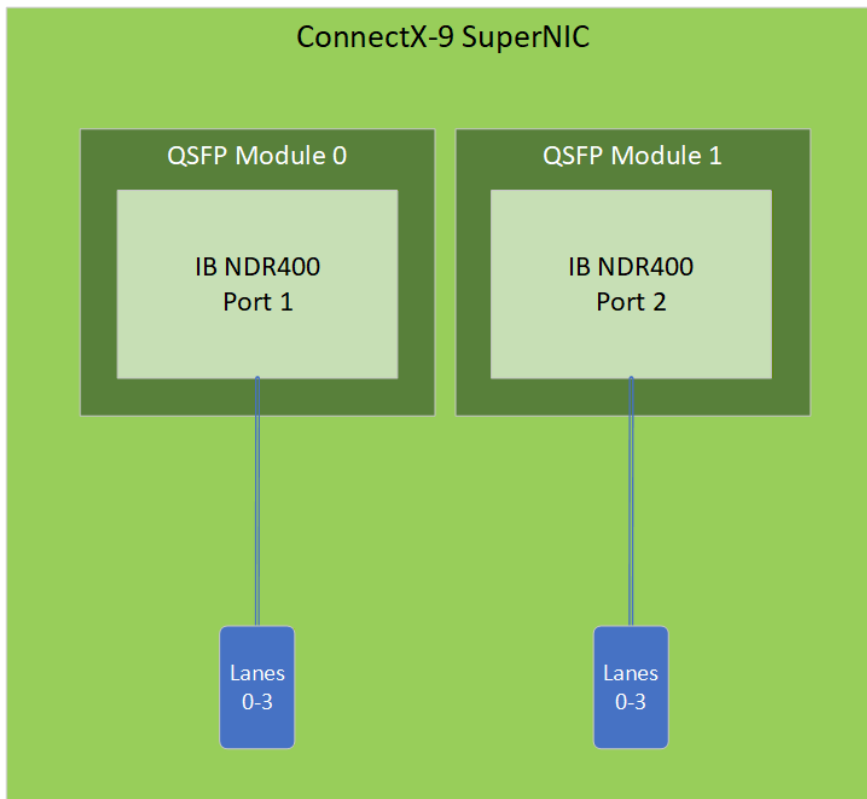

To apply this configuration, use the following mlxconfig commands:

```
mlxconfig -d <device> set LINK_TYPE_P1=1 LINK_TYPE_P2=1
```

6.4 Monitoring

6.4.1 Thermal Sensors

The adapter card incorporates the ConnectX IC, which operates in the range of temperatures between 0°C and 105°C.

Three thermal threshold definitions impact the overall system operation state and are designed to ensure timely application of server-level corrective actions, such as increased cooling, to keep the device temperature in the working range:

- **Warning - 97°C (default)** When the device crosses this threshold, an Over-Temperature Warning message is issued by the management SW. This may be used to increase the cooling of the system (e.g. - by increased Fans RPM). Note that this temperature threshold does not require nor lead to any action by hardware (such as adapter card shutdown).
- **Critical - 102°C (default):** When the device crosses this threshold, an Over-Temperature Critical message is issued by the management SW.
- **Fatal - 110°C:** Upon reaching this temperature, an Over-temperature Fatal message is issued. If the the device continues to heat-up, the FW will automatically shut down upon reaching 115°C threshold.

The card's thermal sensors can be read through the system's SMBus. The user can read these thermal sensors and adapt the system airflow following the readouts and the needs of the above-mentioned IC thermal requirements.

6.4.2 SuperNIC Heatsink

The heatsink is attached to the SuperNIC IC to dissipate the heat from the IC. It is attached by spring-loaded screws.

The SuperNIC IC has a thermal shutdown safety mechanism that automatically shuts down the card in cases of high-temperature events, improper thermal coupling, or heatsink removal.

For the required airflow (LFM) per OPN, please refer to the [Specifications](#) chapter.

7 Troubleshooting

When working with the ConnectX-8 SuperNIC, you may encounter various issues related to connectivity, performance, or configuration. This section outlines common problems, their possible causes, and steps to resolve them.

7.1 General Troubleshooting

NIC Not Detected by the System	<ul style="list-style-type: none">• Ensure that the SuperNIC is placed correctly• Make sure the SuperNIC slot and the SuperNIC are compatible Install the SuperNIC in a different PCI Express slot• Use the drivers that came with the SuperNIC or download the latest• Make sure your motherboard has the latest BIOS• Try to reboot the server
The SuperNIC no longer works	<ul style="list-style-type: none">• Reseat the SuperNIC in its slot or a different slot, if necessary• Try using another cable• Reinstall the drivers for the network driver files may be damaged or deleted• Reboot the server
SuperNICs stopped working after installing another SuperNIC	<ul style="list-style-type: none">• Try removing and re-installing all SuperNICs• Check that cables are connected properly• Make sure your motherboard has the latest BIOS
Link indicator light is off	<ul style="list-style-type: none">• Try another port on the switch• Make sure the cable is securely attached• Check you are using the proper cables that do not exceed the recommended lengths• Verify that your switch and SuperNIC port are compatible
Link light is on, but with no communication established	<ul style="list-style-type: none">• Check that the latest driver is loaded• Check that both the SuperNIC and its link are set to the same speed and duplex settings

7.2 Linux Troubleshooting

Environment Information	<pre>cat /etc/issue uname -a cat /proc/cupinfo grep 'model name' uniq ofed_info -s ifconfig -a ip link show ethtool <interface> ethtool -i <interface_of_Mellanox_port_num> ibdev2netdev</pre>
SuperNIC Detection	<pre>lspci grep -i Mellanox</pre>
Mellanox Firmware Tool (MFT)	<p>Download and install MFT: MFT Documentation Refer to the User Manual for installation instructions. Once installed, run:</p> <pre>mst start mst status flint -d <mst_device> q</pre>
Ports Information	<pre>ibstat ibv_devinfo</pre>
Firmware Version Upgrade	<p>To download the latest firmware version, refer to the NVIDIA Update and Query Utility.</p>
Collect Log File	<pre>cat /var/log/messages dmesg >> system.log journalctl (Applicable on new operating systems) cat /var/log/syslog</pre>

7.3 Windows Troubleshooting

Environment Information	From the Windows desktop choose the Start menu and run: <code>msinfo32</code> To export system information to a text file, choose the Export option from the File menu. Assign a file name and save.
Mellanox Firmware Tool (MFT)	Download and install MFT: MFT Documentation Refer to the User Manual for installation instructions. Once installed, open a CMD window and run: WinMFT <code>mst start</code> <code>mst status</code> <code>flint -d <mst_device> q</code>
Ports Information	<code>vstat</code>
Firmware Version Upgrade	Download the latest firmware version using the PSID/board ID from here . <code>flint -d <mst_device> -i <firmware_bin_file> b</code>
Collect Log File	<ul style="list-style-type: none">• Event log viewer• MST device logs:<ul style="list-style-type: none">• <code>mst start</code>• <code>mst status</code>• <code>flint -d <mst_device> dc > dump_configuration.log</code>• <code>mstdump <mst_device> dc > mstdump.log</code>

8 Finding the GUID/MAC on the SuperNIC

Each SuperNIC is labeled with unique identifiers, including a serial number and specific protocol information; it includes a GUID (for InfiniBand protocols) and a MAC address (for Ethernet protocols, derived from the GUID).



The product revisions indicated on the labels in the following figures do not necessarily represent the latest revisions of the SuperNICs.

Board Label Example

TBD

9 Specifications



The ConnectX-9 SuperNIC is designed and validated for operation in data-center servers and other large environments that guarantee proper power supply and airflow conditions.

The SuperNIC is not intended for installation on a desktop or a workstation. Moreover, installing the adapter card in any system without proper power and airflow levels can impact the SuperNIC's functionality and potentially damage it. Failure to meet the environmental requirements listed in this user manual may void the warranty.



Please install the ConnectX-9 SuperNIC in a PCIe slot capable of supplying the required power and airflow.

9.1 C9180 SuperNICs Specifications



ConnectX-9 SuperNICs with OSFP form factor support RHS (Riding Heatsink) cage only

Physical	SuperNIC Dimensions: PCIe Half Height, Half Length 2.69 in. x 6.58 in. (68.50mm x 168.40mm)		
Interfaces	See Supported Interfaces		
	PCI Express Interface	Gen6 SERDES @ 64GT/s, x16 lanes (Gen 5 compatible) Optional: Additional PCIe x16 Gen6 @ SERDES 32GT/s through the PCIe auxiliary card and MCIO harness	
	Networking Port: Single cage OSFP InfiniBand and Ethernet		
Data Rate	InfiniBand (Default)	XDR/NDR/NDR200/HDR/HDR100	
	Ethernet	800/400/200/100 Gb/s Ethernet	
Protocol Support	InfiniBand: IBTA v1.7 ^a XDR (4 lanes x 200Gb/s per lane) port, NDR (4 lanes x 100Gb/s per lane) port, NDR200 (2 lanes x 100Gb/s per lane) port, HDR (50Gb/s per lane) port, HDR100 (2 lane x 50Gb/s per lane) port.		
	Ethernet: 800GAUI-4 C2M, 400GAUI-2 C2M, 200GAUI-1 C2M, 800GAUI-8 C2M, 400GAUI-4 C2M, 200GAUI-2 C2M, 100GAUI-1 C2M, 200GAUI-4, 400GAUI-8 C2M, 200GAUI-4 C2M, 100GAUI-2 C2M, 50GAUI-1 C2M, CAUI-4 C2M, 25GAUI C2M. 800GBASE-CR4, 400GBASE-CR2, 200GBASE-CR1, 800GBASE-CR8, 400GBASE-CR4, 200GBASE-CR2, 100GBASE-CR1, 200GBASE-CR4, 400GBASE-CR8, 200GBASE-CR4, 100GBASE-CR2, 50GBASE-CR, 100GBASE-CR4, 25GBASE-CR, 25GBASE-CR-S.		
Capabilities	900-9X91E-00EB-ST0	Secure Boot Enabled, Crypto Enabled with x16 PCIe extension option	
	900-9X91E-00EB-DT0	Secure Boot Enabled, Crypto Enabled with x16 PCIe Down-Stream Port Extension Option	
Electrical and Thermal Specifications	Voltage: 12V, 3.3V, 3.3VAUX		
	To be updated in a future version of this document.		
Environmental	Temperature	Operational	0° C to 55° C
		Non-operational	-40° C to 70° C ^b
	Humidity	Operational	10% to 85% relative humidity
		Non-operational	10% to 90% relative humidity
Altitude (Operational)	3050m		
Regulatory	Safety: CB / cTUVus / CE		
	EMC: CE / FCC / VCCI / ICES / RCM / KC		
	RoHS: RoHS Compliant		

Notes:

- a. The ConnectX-9 SuperNICs supplement the IBTA auto-negotiation specification to get better bit error rates and longer cable reaches. This supplemental feature only initiates when connected to another NVIDIA InfiniBand product.
- b. The non-operational storage temperature specifications apply to the product without its package.

C9240 SuperNICs Specifications



ConnectX-9 SuperNICs with OSFP form factor support RHS (Riding Heatsink) cage only

Physical	SuperNIC Dimensions: PCIe Half Height, Half Length 2.61 in. x 6.62 in. (66.40mm x 168.40mm)		
Interfaces	See Supported Interfaces		
	PCI Express Interface	Gen6 SERDES @ 64GT/s, x16 lanes (Gen5 compatible)	
		Optional: Additional PCIe x16 Gen5 @ SERDES 32GT/s through the PCIe auxiliary passive card and MCIO harness	
	Networking Port: Dual-port QSFP112 InfiniBand and Ethernet		
Data Rate	InfiniBand	NDR/HDR/HDR100/EDR/SDR	
	Ethernet (Default)	400/200/100 Gb/s Ethernet	
Protocol Support	InfiniBand: IBTA v1.7 ^a Auto-Negotiation: NDR (4 lanes x 100Gb/s per lane) port, NDR200 (2 lanes x 100Gb/s per lane) port, HDR (50Gb/s per lane) port, HDR100 (2 lane x 50Gb/s per lane), EDR (25Gb/s per lane) port, FDR (14.0625Gb/s per lane), 1X/2X/4X SDR (2.5Gb/s per lane).		
	Ethernet: 400GAUI-4 C2M, 400GBASE-CR4, 200GAUI-2 C2M, 200GAUI-4 C2M, 200GBASE-CR4, 100GAUI-2 C2M, 100GAUI-1 C2M, 100GBASE-CR4, 100GBASE-CR2, 100GBASE-CR1, 50GAUI-2 C2M, 50GAUI-1 C2M, 50GBASE-CR, 50GBASE-R2, 40GBASE-CR4, 40GBASE-R2, 25GBASE-R, 10GBASE-R, 10GBASE-CX4, 1000BASE-CX, CAUI-4 C2M, 25GAUI C2M, XLAUI C2M, XLPPI, SFI		
Capabilities	900-9X91Q-00CN-ST0	x16 PCIe Socket Direct extension option, Secure Boot Enabled, Crypto Enabled	
Electrical and Thermal Specifications	Voltage: 12V, 3.3V, 3.3VAUX		
	The complete electrical and thermal specifications are provided in " <i>NVIDIA ConnectX-9 SuperNIC Product Specifications</i> " document. You can access the document either by logging into NVOnline or by contacting your NVIDIA representative.		
Environmental	Temperature	Operational	0°C to 55°C
		Non-operational	-40°C to 70°C ^b
	Humidity	Operational	10% to 85% relative humidity
		Non-operational	10% to 90% relative humidity
Altitude (Operational)	3050m		
Regulatory	Safety: CB / cTUVus / CE		
	EMC: CE / FCC / VCCI / ICES / RCM / KC		
	RoHS: RoHS Compliant		

Physical	SuperNIC Dimensions: PCIe Half Height, Half Length 2.61 in. x 6.62 in. (66.40mm x 168.40mm)
<p>Notes:</p> <p>a. The ConnectX-9 SuperNICs supplement the IBTA auto-negotiation specification to get better bit error rates and longer cable reaches. This supplemental feature only initiates when connected to another NVIDIA InfiniBand product.</p> <p>b. The non-operational storage temperature specifications apply to the product without its package.</p>	

Cards Mechanical Drawings and Dimensions

 All dimensions are in millimeters. The PCB mechanical tolerance is +/- 0.13mm.

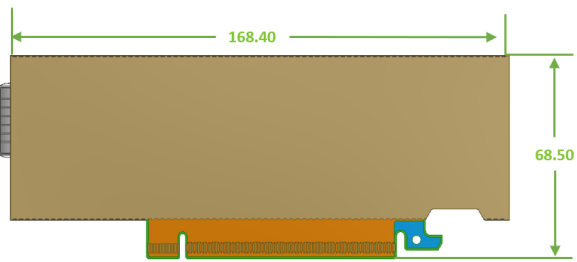
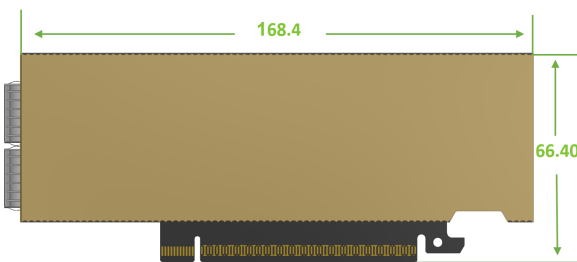
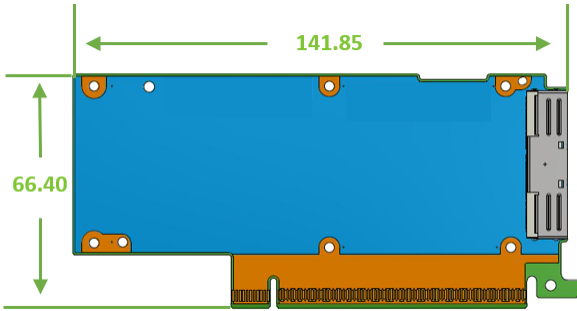
C9180 SuperNICs	C9240 SuperNICs
	
Auxiliary PCIe Connection Card	
	

9.2 Brackets Mechanical Drawings and Dimensions

⚠ All dimensions are in millimeters. The PCB mechanical tolerance is +/- 0.13mm.

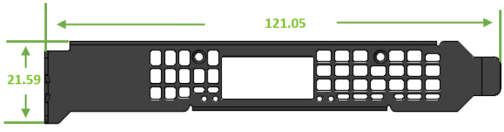
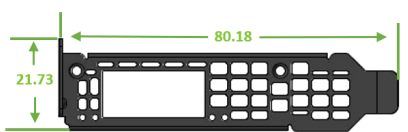
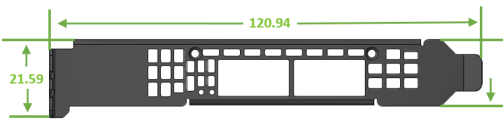
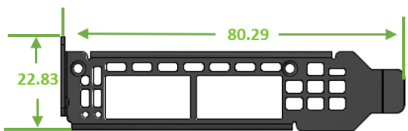
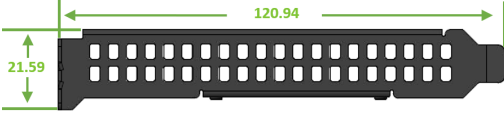
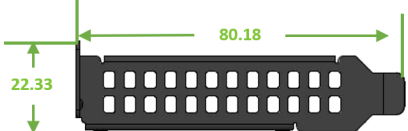
OPNs	Tall Bracket	Short Bracket
C9180 SuperNICs <ul style="list-style-type: none"> • 900-9X91E-00EB-ST0 • 900-9X91E-00EB-DT0 		
C9240 SuperNICs <ul style="list-style-type: none"> • 900-9X91Q-00CN-ST0 		
Auxiliary PCIe Connection Card		

10 PCIe Auxiliary Card Kit

The Socket Direct SuperNIC, which cost-effectively integrates a single SuperNIC and an auxiliary PCIe connection card and MCIO cable connecting the two. Socket Direct enables direct access from each CPU to the network through its dedicated PCIe interface as the card's 32-lane PCIe bus is split into two 16-lane buses, with one bus accessible through a PCIe x16 edge connector and the other bus through an x16 Auxiliary PCIe Connection card. The two cards should be installed into two PCIe x16 slots and connected using an MCIO cable.

The PCIe auxiliary kit can be purchased separately to operate in a dual-socket server. The below table lists the available PCIe auxiliary kit ordering part number.

Model	Ordering Part Number	Description
C9180X	930-9XAX6-0025-000	NVIDIA SocketDirect Auxiliary Kit for Additional PCIe Gen6x16 Connection, 250mm MCIO Harness

10.1 PCIe Auxiliary Card Package Contents

Category	Qty	Item
Cards	1	PCIe x16 Gen6 Auxiliary Connection Card
Cable	1	250mm MCIO cable
Accessories	1	PCIe Auxiliary card short bracket
	1	PCIe Auxiliary card tall bracket (shipped assembled on the Auxiliary card)

There are two available PCIe auxiliary kit functionalities:

1. Utilizing the Socket-Direct capability, where the PCIe extension card is connected to the ConnectX-9 SuperNIC, used as an end-point.
2. Utilizing the Down Stream Port (DSP) extension option, where the PCIe extension card is connected to the ConnectX-9 SuperNIC, used as a root complex for storage devices.

10.2 Socket Direct SuperNICs

The Socket Direct™ technology offers improved performance to dual-socket servers by enabling direct access from each CPU in a dual-socket server to the network through its dedicated PCIe interface. Utilizing the Socket-Direct or the Multi-Host capability, the PCIe extension card is connected to the SuperNIC and is used as an end-point extension.

NVIDIA offers ConnectX-9 Socket Direct, which enables 800Gb/s or 400Gb/s connectivity for servers with PCIe Gen6 capability, respectively. The SuperNIC's 32-lane PCIe bus is split into two 16-lane buses, with one bus accessible through a PCIe x16 edge connector and the other bus through an x16 Auxiliary PCIe Connection card. The two cards should be installed into two PCIe x16 slots and connected using an MCIO harness.

Please order the additional PCIe Auxiliary Card kit to use the SuperNIC in the Socket-Direct configuration. SuperNICs that support Socket Direct can function as separate x16 PCIe cards.

10.3 Down Stream Port (DSP)

The ConnectX-9 SuperNIC with downstream port extension option provides connectivity to the server backplane or PCIe switch through the MCIO connector.

The default PCI interface is x4 x 4 to manage four SSD devices.

10.4 Channel Insertion Loss

Channel insertion loss refers to the reduction in signal power due to the insertion of a device in a transmission line or optical fiber. It is typically measured in decibels (dB).

The table below outlines the channel insertion loss budget for the ConnectX-9 SuperNIC in a PCIe Gen6 architecture (32 GT/s).

The listed values are based on measured data. It is advisable to add a 0.5 dB margin to your system, as channel loss may vary.

Channel Loss at Gen5	Decibels
Total add-in card (bump to Goldfinger) Insertion loss approved by PCI-SIG Gen5	8.5 dB @16GHz
SuperNIC PCIe Lanes (PCORE1)	5 dB @16GHz
Passive PCIe Auxiliary Card	2.5 dB @16GHz
MCIO harness (including connectors)	3.5 dB @16GHz
SuperNIC PCIe interface, PCIe Auxiliary Card, and MCIO harness	11 dB @16GHz

10.5 MCIO Harness Pinouts

The table below lists the MCIO connector pinouts of the MCIO harness included in the PCIe Auxiliary Kit. For the MCIO connector pinouts on the ConnectX-9 SuperNIC, refer to [MCIO Interface](#).

Additional Electrical Information	Description/ Direction	P i n	P i n	Description/ Direction	Additional Electrical Information
	GND	A 1	B 1	GND	
	PETp0	A 2	B 2	PERp0	
	PETn0	A 3	B 3	PERn0	
	GND	A 4	B 4	GND	
	PETp1	A 5	B 5	PERp1	

	PETn1	A 6	B 6	PERn1	
	GND	A 7	B 7	GND	
Logic: Same power requirements as 3V3_AUX in PCIe spec Voltage Level: 3.3V	3V3_AUX (IN)	A 8	B 8	SMBUS_SCL (IN)	Logic: Open-drain Voltage Level: 3.3V Presence of PU/PD: PU 100k ohm
Presence of PU/PD: PD termination 42.2 ohm	FLEXIO0_A	A 9	B 9	SMBUS_SDA (BID)	Logic: Open-drain Voltage Level: 3.3V Presence of PU/PD: PU 100k ohm
	GND	A 10	B 10	GND	
Logic: PCIe REFCLK IN	REFCLK_A_Dp (IN)	A 11	B 11	PERST_A_N (IN)	Logic: Push-pull, active low Voltage Level: 3.3V
Logic: PCIe REFCLK IN	REFCLK_A_Dn (IN)	A 12	B 12	CBL_PRES_A (OUT)	Logic: Active low Voltage Level: 3.3V Presence of PU/PD: PD 200 ohm Recommended implementation on System level: PU 100k ohm
	GND	A 13	B 13	GND	
	PETp2	A 14	B 14	PERp2	
	PETn2	A 15	B 15	PERn2	
	GND	A 16	B 16	GND	
	PETp3	A 17	B 17	PERp3	
	PETn3	A 18	B 18	PERn3	
	GND	A 19	B 19	GND	
	PETp4	A 20	B 20	PERp4	

	PETn4	A 2 1	B 2 1	PERn4	
	GND	A 2 2	B 2 2	GND	
	PETp5	A 2 3	B 2 3	PERp5	
	PETn5	A 2 4	B 2 4	PERn5	
	GND	A 2 5	B 2 5	GND	
Presence of PU/PD: PD termination 42.2 ohm	FLEXIO1_A/ REFCLK_B_Dp	A 2 6	B 2 6	FLEXIO3_A/ I2C_M_SDA_A (NC)	Presence of PU/PD: PD termination 42.2 ohm
Presence of PU/PD: PD termination 42.2 ohm	FLEXIO2_A/ REFCLK_B_Dn	A 2 7	B 2 7	FLEXIO4_A/ I2C_M_SCL_A (NC)	Presence of PU/PD: PD termination 42.2 ohm
	GND	A 2 8	B 2 8	GND	
Presence of PU/PD: PD termination 42.2 ohm	FLEXIO7_A	A 2 9	B 2 9	PERST_B_N (IN)	Presence of PU/PD: PD termination 42.2 ohm
Presence of PU/PD: PD termination 42.2 ohm	FLEXIO8_A	A 3 0	B 3 0	CBL_PRES_B (OUT)	Presence of PU/PD: PD termination 42.2 ohm
	GND	A 3 1	B 3 1	GND	
	PETp6	A 3 2	B 3 2	PERp6	
	PETn6	A 3 3	B 3 3	PERn6	
	GND	A 3 4	B 3 4	GND	
	PETp7	A 3 5	B 3 5	PERp7	

	PETn7	A 3 6	B 3 6	PERn7	
	GND	A 3 7	B 3 7	GND	
		Key			
	GND	A 3 8	B 3 8	GND	
	PETp8	A 3 9	B 3 9	PERp8	
	PETn8	A 4 0	B 4 0	PERn8	
	GND	A 4 1	B 4 1	GND	
	PETp9	A 4 2	B 4 2	PERp9	
	PETn9	A 4 3	B 4 3	PERn9	
	GND	A 4 4	B 4 4	GND	
	PETp10	A 4 5	B 4 5	PERp10	
	PETn10	A 4 6	B 4 6	PERn10	
	GND	A 4 7	B 4 7	GND	
	PETp11	A 4 8	B 4 8	PERp11	
	PETn11	A 4 9	B 4 9	PERn11	
	GND	A 5 0	B 5 0	GND	

	PETp12	A 5 1	B 5 1	PERp12	
	PETn12	A 5 2	B 5 2	PERn12	
	GND	A 5 3	B 5 3	GND	
	PETp13	A 5 4	B 5 4	PERp13	
	PETn13	A 5 5	B 5 5	PERn13	
	GND	A 5 6	B 5 6	GND	
	PETp14	A 5 7	B 5 7	PERp14	
	PETn14	A 5 8	B 5 8	PERn14	
	GND	A 5 9	B 5 9	GND	
	PETp15	A 6 0	B 6 0	PERp15	
	PETn15	A 6 1	B 6 1	PERn15	
	GND	A 6 2	B 6 2	GND	

10.6 PCIe Auxiliary Kit Technical Specifications

10.6.1 Technical Specifications

Physical	PCIe Auxiliary Card Size: 5.69 in. x 2.61 in. (144.75mm x 66.40mm) One MCIO cable: Length 250mm
PCIe Connectivity	PCI Express Gen6: SERDES @ 16 GT/s, x16 lanes (Gen 3.0 compatible)

Power Consumption	Voltage: 12V, 3.3V_PClE, 3.3V_AUX		
Environmental	Temperature	Operational	0 °C to 55 °C
		Non-operational	-40 °C to 70 °C
	Humidity	Operational	10% to 85% relative humidity
		Non-operational	10% to 90% relative humidity
Altitude (Operational)	3050m		
Regulatory	Safety: CB / cTUVus / CE		
	EMC: CE / FCC / VCCI / ICES / RCM / KC		
	RoHS: RoHS Compliant		

10.6.2 PCIe Auxiliary Card Mechanical Drawings and Dimensions

 All dimensions are in millimeters. The PCB mechanical tolerance is +/- 0.13mm.

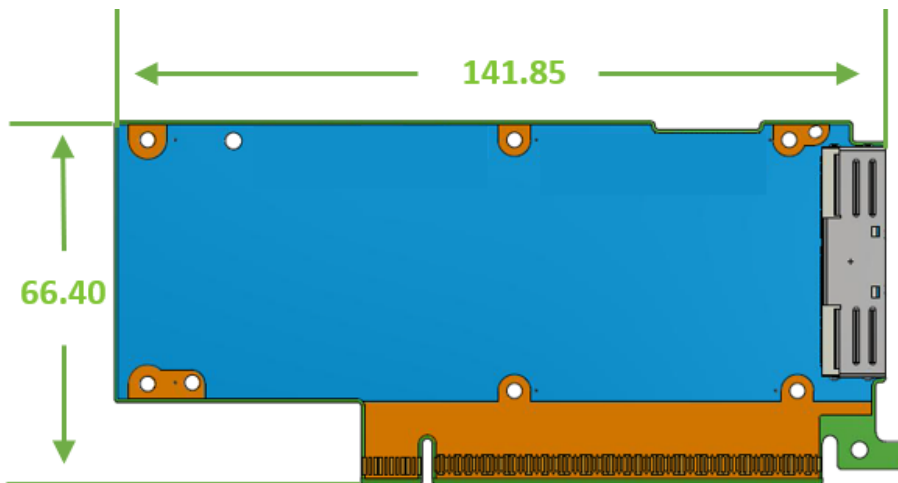

10.6.3 Bracket Mechanical Drawings and Dimensions

Auxiliary PCIe Connection Card Tall Bracket	Auxiliary PCIe Connection Card Short Bracket
<p>Dimensions: 120.94 mm length, 21.59 mm height.</p>	<p>Dimensions: 80.18 mm length, 22.33 mm height.</p>

11 Document Revision History

Date	Comments/Changes
Dec. 2025	<ul style="list-style-type: none">• Added support for OPN 900-9X91Q-00CN-ST0 across the document• Updated Port Configurations
July. 2025	Updated OPNs' marketing description
May. 2025	First release

Notice

This document is provided for information purposes only and shall not be regarded as a warranty of a certain functionality, condition, or quality of a product. Neither NVIDIA Corporation nor any of its direct or indirect subsidiaries and affiliates (collectively: "NVIDIA") make any representations or warranties, expressed or implied, as to the accuracy or completeness of the information contained in this document and assumes no responsibility for any errors contained herein. NVIDIA shall have no liability for the consequences or use of such information or for any infringement of patents or other rights of third parties that may result from its use. This document is not a commitment to develop, release, or deliver any Material (defined below), code, or functionality.

NVIDIA reserves the right to make corrections, modifications, enhancements, improvements, and any other changes to this document, at any time without notice. Customer should obtain the latest relevant information before placing orders and should verify that such information is current and complete.

NVIDIA products are sold subject to the NVIDIA standard terms and conditions of sale supplied at the time of order acknowledgement, unless otherwise agreed in an individual sales agreement signed by authorized representatives of NVIDIA and customer ("Terms of Sale"). NVIDIA hereby expressly objects to applying any customer general terms and conditions with regards to the purchase of the NVIDIA product referenced in this document. No contractual obligations are formed either directly or indirectly by this document.

NVIDIA products are not designed, authorized, or warranted to be suitable for use in medical, military, aircraft, space, or life support equipment, nor in applications where failure or malfunction of the NVIDIA product can reasonably be expected to result in personal injury, death, or property or environmental damage. NVIDIA accepts no liability for inclusion and/or use of NVIDIA products in such equipment or applications and therefore such inclusion and/or use is at customer's own risk.

NVIDIA makes no representation or warranty that products based on this document will be suitable for any specified use. Testing of all parameters of each product is not necessarily performed by NVIDIA. It is customer's sole responsibility to evaluate and determine the applicability of any information contained in this document, ensure the product is suitable and fit for the application planned by customer, and perform the necessary testing for the application in order to avoid a default of the application or the product. Weaknesses in customer's product designs may affect the quality and reliability of the NVIDIA product and may result in additional or different conditions and/or requirements beyond those contained in this document. NVIDIA accepts no liability related to any default, damage, costs, or problem which may be based on or attributable to: (i) the use of the NVIDIA product in any manner that is contrary to this document or (ii) customer product designs.

No license, either expressed or implied, is granted under any NVIDIA patent right, copyright, or other NVIDIA intellectual property right under this document. Information published by NVIDIA regarding third-party products or services does not constitute a license from NVIDIA to use such products or services or a warranty or endorsement thereof. Use of such information may require a license from a third party under the patents or other intellectual property rights of the third party, or a license from NVIDIA under the patents or other intellectual property rights of NVIDIA.

Reproduction of information in this document is permissible only if approved in advance by NVIDIA in writing, reproduced without alteration and in full compliance with all applicable export laws and regulations, and accompanied by all associated conditions, limitations, and notices.

THIS DOCUMENT AND ALL NVIDIA DESIGN SPECIFICATIONS, REFERENCE BOARDS, FILES, DRAWINGS, DIAGNOSTICS, LISTS, AND OTHER DOCUMENTS (TOGETHER AND SEPARATELY, "MATERIALS") ARE BEING PROVIDED "AS IS." NVIDIA MAKES NO WARRANTIES, EXPRESSED, IMPLIED, STATUTORY, OR OTHERWISE WITH RESPECT TO THE MATERIALS, AND EXPRESSLY DISCLAIMS ALL IMPLIED WARRANTIES OF NONINFRINGEMENT, MERCHANTABILITY, AND FITNESS FOR A PARTICULAR PURPOSE. TO THE EXTENT NOT PROHIBITED BY LAW, IN NO EVENT WILL NVIDIA BE LIABLE FOR ANY DAMAGES, INCLUDING WITHOUT LIMITATION ANY DIRECT, INDIRECT, SPECIAL, INCIDENTAL, PUNITIVE, OR CONSEQUENTIAL DAMAGES, HOWEVER CAUSED AND REGARDLESS OF THE THEORY OF LIABILITY, ARISING OUT OF ANY USE OF THIS DOCUMENT, EVEN IF NVIDIA HAS BEEN ADVISED OF THE POSSIBILITY OF SUCH DAMAGES. Notwithstanding any damages that customer might incur for any reason whatsoever, NVIDIA's aggregate and cumulative liability towards customer for the products described herein shall be limited in accordance with the Terms of Sale for the product.

Trademarks



NVIDIA, the NVIDIA logo, and Mellanox are trademarks and/or registered trademarks of NVIDIA Corporation and/or its affiliates in the U.S. and in other countries. Other company and product names may be trademarks of the respective companies with which they are associated.

Copyright

© 2026 NVIDIA Corporation & affiliates. All Rights Reserved.

